



STRATA_HEAT™

Wi-Fi Thermostat



Operating Manual



Pack Contents



x1



x1



x2



x1

Contents

Safety Information	3
Step 1 – Installation	3
Step 2 – Wiring Connections	4
Table 1.0 – Thermostat use cases	5
Wiring Diagrams – over 15 Amps	6
Step 3 – Thermostat Mounting	7
Step 4 – Initial Setup	7-8
Welcome to the STRATA_HEAT™ Wi-Fi Thermostat	9
How to quickly change the temperature	9
How to quickly change mode	9
Heating	10
How to set a program	10
Setback Temperature	10
How to set into Manual Mode	11
How to set a Temporary Override	11
Energy Monitor	12
Geo Location Settings	12
Settings	13-14
Notifications and Error codes	15
Troubleshooting	15-16
Wi-Fi Troubleshooting	17
Technical Specifications	18
Warranty	19

Safety Information

- ❑ The STRATA_HEAT™ Wi-Fi Thermostat must be installed by a qualified electrician. It requires a permanent 110V – 240V AC, 60Hz supply. The STRATA_HEAT Wi-Fi Thermostat contains a Class A GFCI with 5mA trip level and wiring must conform to local electrical code.
- ❑ Isolate the STRATA_HEAT Wi-Fi Thermostat from the mains supply throughout the installation process.
- ❑ Install the STRATA_HEAT Wi-Fi Thermostat in an area with good ventilation. It should not be beside a window/door, in direct sunlight or above another heat generating device (e.g. radiator or TV).
- ❑ Ensure the distance from your router to the STRATA_HEAT Wi-Fi Thermostat is not excessive. This will ensure the wireless connection is not subject to range or interference issues once installed.
- ❑ Conduits are only required where it is mandated by state or provincial code. Please refer to local electrical code for compliant applications.
- ❑ The STRATA_HEAT Wi-Fi Thermostat and its packaging are not toys; do not allow children to play with them. Small components and packaging present a risk of choking or suffocation.
- ❑ The STRATA_HEAT Wi-Fi Thermostat is suitable for indoor use only. It must not be exposed to moisture, vibrations, mechanical loads or temperatures outside of its rated values.
- ❑ For safety and licensing reasons, unauthorised change and/or modification of the STRATA_HEAT Wi-Fi Thermostat is not permitted.

Step 1 – Installation

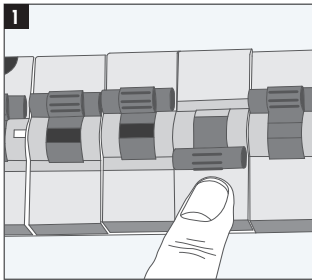

1
Isolate the STRATA_HEAT Wi-Fi Thermostat and supply from the mains supply.

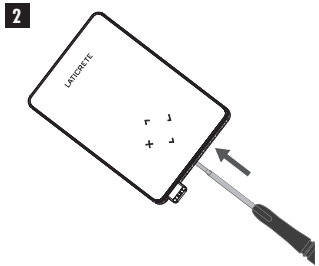

2
Unclip the display from the power base

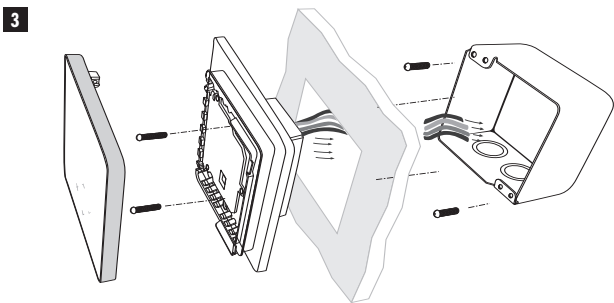

3
Install a 3-1/2" (89 mm) deep single gang or 2-gang box with mud ring in your preferred thermostat location. Pull wires (heater, supply and sensor) through gang box and complete terminal wiring.

Step 2 – Wiring Connections

WARNING!

The STRATA_HEAT™ WiFi Thermostat must be installed by a qualified electrician in accordance with National Electrical Code.

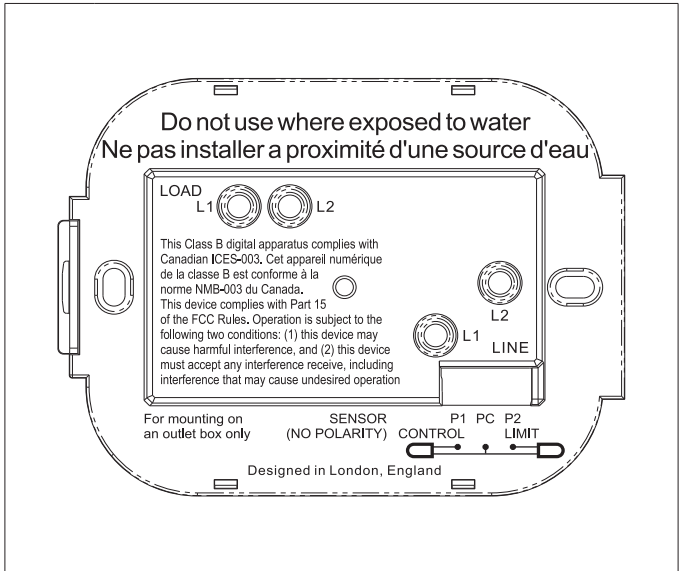

Wiring Connections

LOAD L1 & L2	Heater Load Max.15A (1800W/120V, 3600W/240V)
LINE L1	Supply Live (120 V)
LINE L2	Supply Neutral (120 V) / Supply Live (240 V)
P1 & PC	Probe 1 – Floor/Air Control Sensor (No Polarity) Floor or air temperature reading for scheduled control
P2 & PC	Probe 2 – Limit Sensor (No Polarity)

See Table 1.0 for thermostat use cases

NOTE: The function of Probe 1, Probe 2 from Control/Limit Sensor can be swapped in Advanced Settings; Sensors & Application.

Table 1.0 – Thermostat use cases

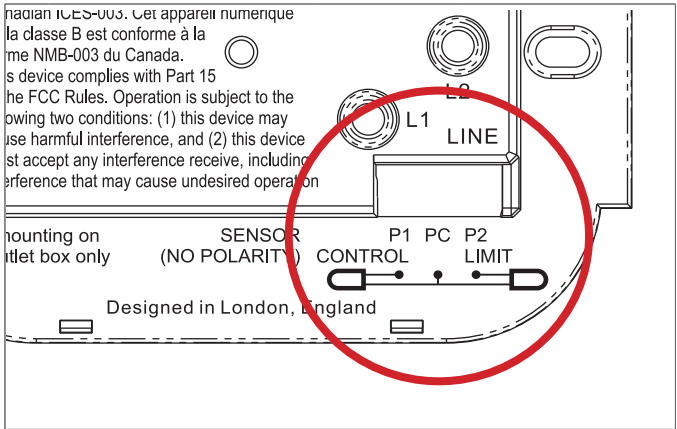

#	Use Case	Control	Limit Sensor
1	Thermostat IN room Air temperature schedule No floor limit	Internal Air Sensor	None
2*	Thermostat IN/OUT of room Floor temperature schedule Floor limit	P1 & PC Floor Sensor	None
3	Thermostat IN room Floor temperature schedule Air limit	P1 & PC Floor Sensor	Internal Air Sensor
4	Thermostat OUT of room Air temperature schedule No floor limit	P1 & PC Air Sensor	None
5**	Thermostat IN room Air temperature schedule Floor limit	Internal Air Sensor	P2 & PC Floor Limit
6	Thermostat IN/OUT of room Floor temperature schedule Floor limit	P1 & PC Floor Sensor	P2 & PC Floor Limit
7	Thermostat OUT of room Air temperature schedule Floor limit	P1 & PC Air Sensor	P2 & PC Floor Limit
8	Thermostat IN/OUT of room Regulator schedule No limit	Reg.	None
9	Thermostat IN room Regulator schedule Air limit	Reg.	Internal Air Sensor
10	Thermostat IN/OUT of room Regulator schedule No limit	Reg.	None
11	Thermostat IN/OUT of room Regulator schedule Floor limit	Reg.	P2 & PC Floor Limit
12	Thermostat IN/OUT of room Regulator schedule Floor limit	Reg.	P2 & PC Floor Limit

2* Recommended when thermostat is **OUT** of the heated room

5** Recommended when thermostat is **IN** the heated room

NOTE: For thermostat use cases 6 & 7 an additional sensor will be required.

Wiring Diagrams

Heating Load connected to STRATA_HEAT™ Wi-Fi Thermostat and Relay 25 – Max. 40 Amps

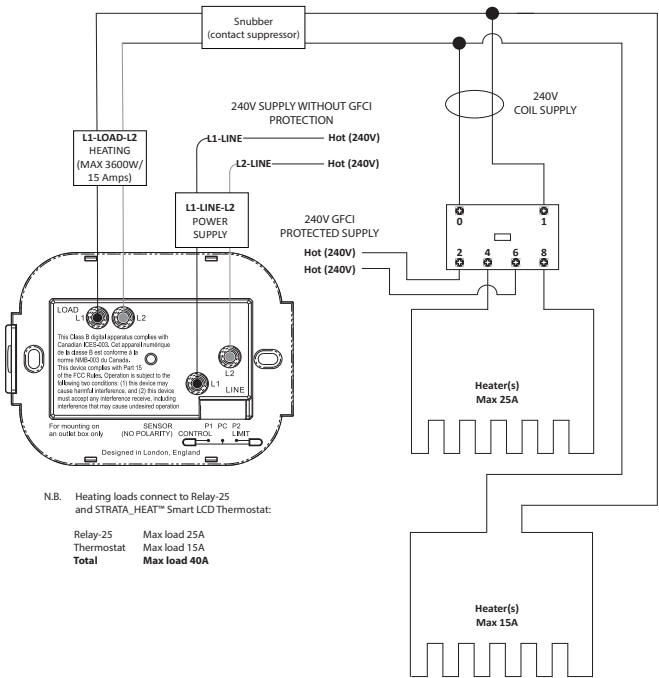

N.B. Heating loads connect to Relay-25 and STRATA_HEAT™ Smart LCD Thermostat:

Relay-25	Max load 25A
Thermostat	Max load 15A
Total	Max load 40A

Heating Load connected to Relay 25 – Max. 25 Amps

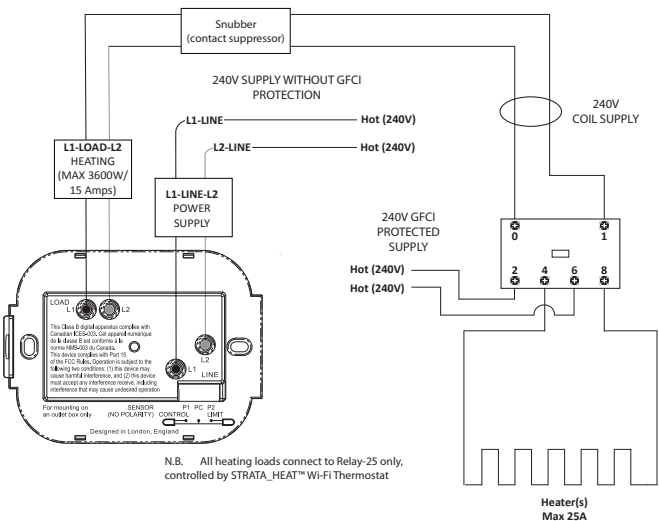

N.B. All heating loads connect to Relay-25 only, controlled by STRATA_HEAT™ Wi-Fi Thermostat

Step 3 – Thermostat Mounting

1

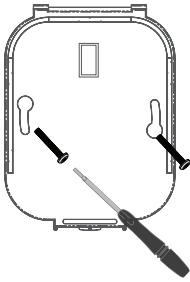

Insert fixing screws through mounting holes of the power base and tighten.

2



Re-attach the display to the power base. You can now restore power to the circuit and power up the STRATA_HEAT™ Wi-Fi Thermostat.

3

System type	Input wattage	Input efficiency	Thermostat application (1-12). See table 1.0	Wi-Fi Setup Open MySTRATA_HEAT app. Scan QR Code
1,500W eUFH	1,500W	90%		
2,000W hUFH	2,000W			
30,000W Conventional	30,000W			
1,500W eUFH + relay	1,500W			

Follow the on screen icons to set up your system.



Accept



Back/Cancel



Up/Down
Change value/setting

Step 4 – Initial Setup

1



Download the MySTRATA_HEAT App.

2

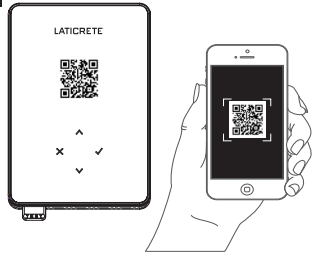

Open the MySTRATA_HEAT App and scan the QR Code on the STRATA_HEAT Wi-Fi Thermostat screen protector or on reverse of the display. Follow the instructions in the App to complete setup.



✓	Next/Accept
✗	Back/Cancel
^	Up/Down
∨	Change value/setting

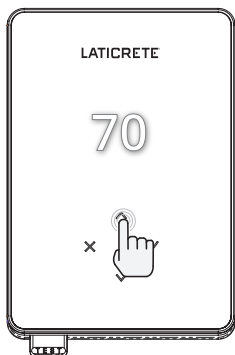

How to quickly change the temperature

Press ^ / ∨ to change your target temperature.

If in program mode this will set a temporary override until your next heating period. See "How to set a temporary override".

If in manual mode this will set a fixed target temperature. See "How to set into Manual Mode"

Once the target temperature is set above current floor/air temperature the heating indicator (●) will appear in the top right hand corner.

How to quickly change mode

Mode select allows you to quickly change from manual mode, program mode or simply switch the heating off.

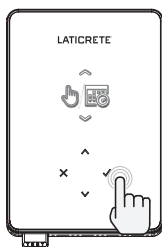
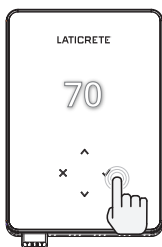

Manual Mode



Program Mode



Heating OFF

Heating

How to set a program

Setting a "Program" allows you to set comfort temperatures at set times throughout the day. Days can be programmed individually, all days the same or weekdays as a block and weekends as a block, the choice is yours.

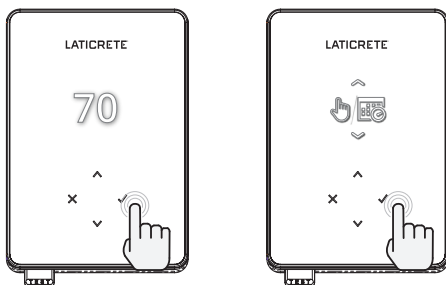

Edit Program



1 2 3 4 5 6 7 >

To select the days you wish to program press \wedge / \vee . A bar will appear below the day of the week. Press \checkmark to move to the next day.



Press \checkmark to set a program.



Set the start time, followed by target temperature and finally the end time for that period. Press \checkmark to accept.



To add/remove heating period, Press \checkmark to on the plus/minus. Up to 5 periods can be set.



Scroll to the tick and Press \checkmark to confirm your program.



Setback temperature



Set setback temperature. The setback temperature is a lower energy efficient temperature when outside of a heating period.

Heating

How to set into Manual Mode

Setting into "Manual" mode allows you to set a fixed target temperature for the thermostat to achieve. The thermostat will continue to maintain this temperature until another operating mode or temperature is selected.

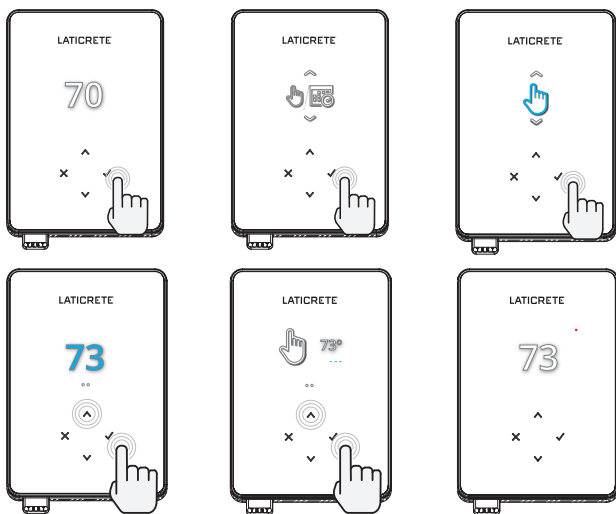

Sets the target temperature indefinitely.



Set the duration of the manual mode.

How to set a Temporary Override

Setting a temporary override allows you to set a target temperature which will override your current heating program until your next heating period or for a set duration.



Sets the override until next scheduled heating period.



Sets the duration of the override.

Energy Monitor

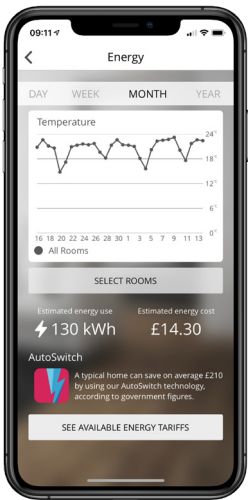

How Energy Monitor works

The STRATA_HEAT™ Wi-Fi Thermostat learns how you use your system and how your house reacts to heating and weather. Using the MySTRATA_HEAT App, energy monitoring will show the amount of energy consumed over a certain time period. This will be calculated through system power multiplied by efficiency and run time.

You will need to enter the power of your system, and in some cases, the efficiency. If you do not know these, speak to your installer or system manufacturer.

Geo Location Settings

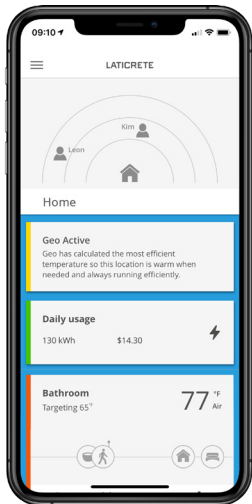

How Geo Location works

Geo is a unique technology developed by LATICRETE and built into the MySTRATA_HEAT App that uses an advanced algorithm to understand the most efficient heat settings for your home.

Working automatically; it learns your routines and location through background communication with your smartphone and lowers temperatures when you are away, only rising them up to your ideal comfort temperature in time for your arrival home.

Geo will operate when the thermostat is in the program or manual run modes. It is turned off by default. Use the MySTRATA_HEAT App to switch Geo on.

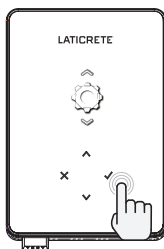
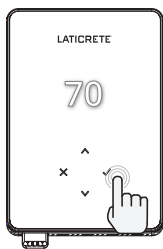

Date and time

6-5-2021
13:00

Set the current date and time.
Press ✓ to begin, press ^/∨ to change date/time.
Press ✓ to confirm.



Thermostat application



Swaps probe usage, 1 being the Control Sensor Probe and 2 being the Limit Sensor Probe. Press ^/∨ to swap probe usage. Press ✓ to confirm.



See Table 1.0 Thermostat Application.
Press ^/∨ to change application. Press ✓ to confirm.



10K

Change Control Sensor Probe 1 (**5 & 6**) type.
Set between 5, 10, 12, 15, 100K sensor settings.



10K

Change Limit Sensor Probe 2 (**6 & 7**) type.
Set between 5, 10, 12, 15, 100K sensor settings.



Set Air limit



Set Floor limit



Set display brightness



Set active brightness



Day standby brightness



Night standby brightness

Settings



Change homescreen override color



Select the override color



Open window function



The windows open detection feature is designed to switch off heating to save energy when the thermostat detects that a window or door has been opened.



Display lock



Switch display lock on

0 0 0 0

Set display lock code



Switch display lock off



Wi-Fi



Wi-Fi Setup



Open MySTRATA_HEAT App and scan the QR code on the back of the STRATA_HEAT™ WiFi Thermostat display to complete Wi-Fi setup.















Factory reset





Factory reset will erase all of your settings and restore the STRATA_HEAT WiFi Thermostat to factory defaults.



Notifications & Error codes

	Date and time needs to be set		Heating switched OFF
	Open window function triggered		Display locked
	Temporary override enabled		Sensor P2 (6 & 7) error
	Holiday mode enabled. (Configured in MySTRATA_HEAT App)		Sensor P1 (5 & 6) not connected / damaged or Internal air sensor fault
	Frost protect enabled. (Configured in MySTRATA_HEAT App)		Wi-Fi not setup
	GFCI tripped		Relay failure

Troubleshooting

Display is blank	Power	(Electrician Required) Electrician required to verify power is going to the STRATA_HEAT™ W-iFi Thermostat and that it is correctly wired.
	Control (5 & 6) / Internal Air sensor error	1. Please see Table 1.0 and ensure you have selected the correct thermostat application.
	Limit Sensor Error (6 & 7)	2. (Electrician Required) Electrician required to verify that the floor sensor has been wired correctly. If it is correctly wired the electrician will need to check the resistance of the floor sensor using a multi meter. For temperatures between 68°F – 86°F (20°C – 30°C) the resistance of the floor sensor should measure between 8K ohms and 12K ohms. If the electrician finds a fault, and the thermostat is in the room to be heated then it can be set into “Air Mode”. To set into “Air Mode”, see Table 1.0 Thermostat application. If “---” still remains when set into air mode the thermostat will have to be replaced.
Heating is coming on earlier than programmed times	Adaptive learning (Early start) On	Adaptive learning (Early start) will use the historic heating/cooling rates for the time of day, historic external temperatures and the forecast external temperatures, to work out the heating start time in order to reach the comfort time at the start of the comfort period. It will only work in Program Mode.
Wi-Fi Error Symbol 	Wi-Fi not setup	1. Download and open the MySTRATA_HEAT App 2. Remove STRATA_HEAT W-iFi Thermostat from the wall 3. Scan QR code on the back of the display 4. Place thermostat back on the wall and power-up 5. Thermostat will be in pairing mode for 1 minute. App should automatically connect to phone 6. Follow instructions in App
	Wi-Fi disconnected	Follow the step above to try and to re-connect to the Wi-Fi Network. If the thermostat still fails to connect, see Wi-Fi Troubleshooting.

Troubleshooting

Clock Icon 	Time and Date not set	Connect the STRATA_HEAT™ WiFi Thermostat to a Wi-Fi network or alternatively set the time and date from the settings menu.
GFCI Icon 	GFCI test button	<p>The GFCI feature is used to detect any leakage of current from your heating system. During a ground fault the two lines of the load will be cut off. Once your thermostat is installed and connected to a power supply you can test the GFCI function by increasing the set temperature until heating is on – the heat up icon (●) will be illuminated – and pressing the “TEST” button.</p> <p>If your test is successful you will see the GFCI error icon and you will need to hold “X” for 3 seconds in order to restore heating operation.</p>
	Heater error	<p>The GFCI has tripped due to a fault in the heater.</p> <p>(Electrician Required) Electrician required to verify that the heater has been wired correctly. If correctly wired please conduct a resistance test and insulation resistance test on the heater to see if damage has occurred.</p>
Relay icon 	Relay error	<p>The STRATA_HEAT WiFi Thermostat has detected that one of the relays has FAILED.</p> <p>Please contact LATICRETE</p>

Wi-Fi Troubleshooting

Before following the troubleshooting guide below please check the following:

1. The password is WPA2 protected.
2. The router is set to a 2.4 GHz band. (802.11 b, g, n, b/g mixed, b/g/n mixed)

NOTE: If you need to change any of the items listed above, please refer to your router manual.

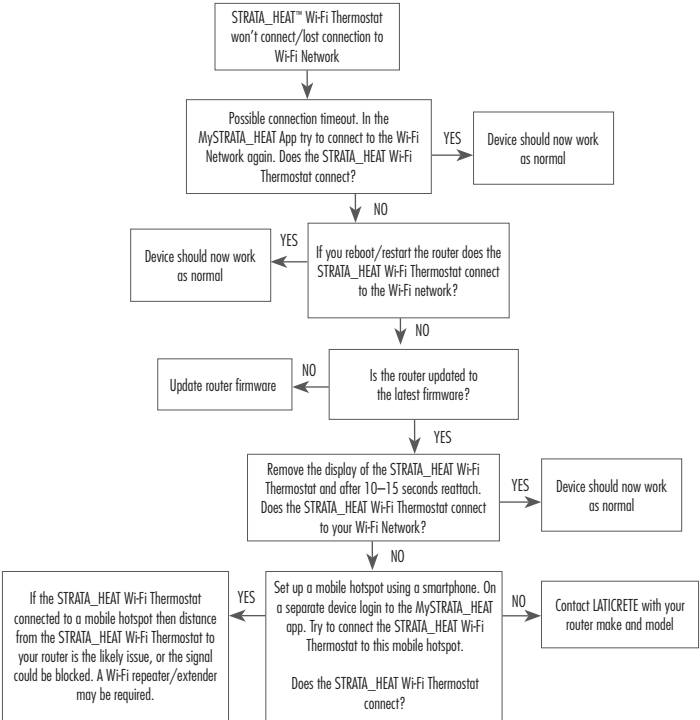

Technical Specifications

Model	RSW-XX-YY-ZZ
Operating Voltage	110V - 240V AC +/-15% 50Hz/60Hz
Protection Class	II <input type="checkbox"/>
Max. Load	15A resistive (120 V – 1800W, 240 V – 3600W)
GFCI	Class A GFCI with 5mA trip level
Rated impulse voltage	4000V
Automatic action	100,000
Disconnection means	1B
Pollution degree	2
Max. Ambient Temperature	40°C / 104°F (T40)
Relative Humidity	80%
IP Rating	IP30
Sensors	Floor/Air
Sensor Type	NTC10K @ 25°C
Operating Frequency	2401 – 2484MHz
Max. Radio-Frequency Power Transmitted	20dBm
Compatibility	Electric Floor Heating and Baseboard Heating
Standards	UL-60730-1 UL-60730-2-9 UL-943 CAN/CSA-E60730-1 CAN/CSA-E60730-2-9 CAN/CSA-C22.2 No. 144.1 FCC 47 CFR Part 15, ICES-003
Warranty	1 Year
Approvals	ETL Intertek

Warranty

LATICRETE warrants this product, to be free from defects in the workmanship or materials, under normal use and service, for 1 year from the date of purchase by the consumer.

If at any time during the warranty period the product is determined to be defective, LATICRETE shall repair or replace it, at LATICRETE's option.

If the product is defective, please either;

Return it, with a bill of sale or other dated proof of purchase, to the place from which you purchased it, or Contact LATICRETE. LATICRETE will determine whether the product should be returned or replaced.

The 1 year warranty only applies if the product is registered with LATICRETE within 30 days after purchase. Registration can be completed online at www.laticrete.com

This warranty does not cover removal or re-installation costs and shall not apply if it is shown by LATICRETE that the defect or malfunction was caused by failure to follow the instruction manuals, incorrect installation or damage which occurred while the product was in the possession of a consumer. The sole responsibility of LATICRETE shall be to repair or replace the product within the terms stated above. This warranty does not extend to any associated software such as apps or portals.

LATICRETE SHALL NOT BE LIABLE FOR ANY LOSS OR DAMAGE OF ANY KIND, INCLUDING ANY INCIDENTAL OR CONSEQUENTIAL DAMAGES RESULTING, DIRECTLY OR INDIRECTLY, FROM ANY BREACH OF ANY WARRANTY, EXPRESS OR IMPLIED, OR ANY OTHER FAILURE OF THIS PRODUCT. THIS WARRANTY IS THE ONLY EXPRESS WARRANTY LATICRETE MAKES ON THIS PRODUCT. THE DURATION OF ANY IMPLIED WARRANTIES, INCLUDING THE WARRANTIES OF MERCHANTABILITY AND FITNESS FOR A PARTICULAR PURPOSE, IS HEREBY LIMITED TO THE ONE-YEAR DURATION OF THIS WARRANTY.

This Warranty does not affect your statutory rights.





LATICRETE International, Inc. ■ One LATICRETE Park North, Bethany, CT 06524-3423 USA
1.800.243.4788 ■ +1.203.393.0010 ■ www.laticrete.com

DS-10048-0122 ©2022 LATICRETE International, Inc. All trademarks shown are the intellectual properties of their respective owners.