

# RAMMERS



SOLUTIONS THAT LAST



## R422 & R442 SERIES

The **R422 & R442 Series Rammers** are ideally suited for the compaction of granular, mixed and cohesive soils in confined areas. A mainstay in contractor and municipal fleets, the R422 & R442 offer highly productive percussion rammers at less than 145 or 150 lbs. respectively. The contoured



R442

fuel tank provides the largest fuel capacity in its class and effectively baffles engine noise. Power is supplied by Honda engines.

- 4-cycle engine
- Elevated bellows placement for trench applications
- Polyethylene slide bearings provide minimal internal wear
- 11" high density, ductile cast iron tamping shoe
- 4" and 6" trench shoes available for the R422



R422

US & International Patents

SPECIFICATIONS	R422H	R442H
Shoe Size	11 x 13 in (28 x 33 cm)	11 x 13 in (28 x 33 cm)
Operating Weight	145 lb (66 kg)	150 lb (68 kg)
Engine Option	Honda GX100 (98 cm <sup>3</sup> )	Honda GX100 (98 cm <sup>3</sup> )
Travel Speed	Up to 55 ft/min (16 m/min)	Up to 55 ft/min (16 m/min)
Compaction Depth*	Up to 18 in (45 cm)	Up to 18 in (45 cm)

\* Clean sand, optimum moisture. MBW recommends that lifts not exceed 12" of granular soil, 9" of cohesive soil.

Percussion rate of up to 750 blow/min; Fuel capacity of 4.6 qt (4.3 l); Engine 3600 rpm  
( ) Metric Measurements. Specifications subject to change without notice.

## RAMMER FEATURES

The secret to our success...

MBW achieves unmatched durability by using high-density non-metallic slide bearings and spring separators. These components last up to 6 times longer than their metal counterparts, create less friction and heat, preserve lubricant integrity, and produce less internal load for the engine to overcome. Compression springs made of stress relieved, chrome-silicon alloy steel and a percussion housing of lightweight, durable aluminum alloy provide the strength for all MBW rammers.

### R422 Series

Optional 4" and 6" trench shoes available as well as a 6" extension for deeper trench application. The unique shoe design keeps rammer on surface of lift.



### Hand/Arm Vibration

MBW is committed to reducing hand/arm vibration on its entire range of rammers. We have made significant progress without cutting back on rammer compaction performance. Hand/arm vibration levels have decreased between 25 & 60% across the range.



### Smart Rammer

The integral tachometer/hour meter ensures that the rammer is operating at maximum capacity. It also informs service personnel of proper maintenance intervals. Optional on the R422 and R442, standard on the R482/483.



## SMART RAMMER SERIES

The Smartest Rammers in the industry, this MBW line is equipped with integral tachometers and hour meters that indicate when maximum operational performance is being reached and when maintenance intervals are needed. The result is higher productivity and increased service life. Weighs between 158-177 lbs. (72-80 kg).

Models R482R and R483R are recommended for altitude above 4000 ft.



Smart Rammers are available with a choice of two engines which provide sure starts and long-term low maintenance.

- Robin EH12 4-cycle
- Honda GX100 4-cycle

US & International Patents

SPECIFICATIONS	R482R	R482H	R483R	R483H
Shoe Size	11 x 13 in (28 x 33 cm)	11 x 13 in (28 x 33 cm)	13 x 15 in (33 x 38 cm)	13 x 15 in (33 x 38 cm)
Operating Weight	170 lb (77 kg)	158 lb (72 kg)	177 lb (80 kg)	165 lb (75 kg)
Engine Option	Robin EH12 (120 cm <sup>3</sup> )	Honda GX100 (98 cm <sup>3</sup> )	Robin EH12 (120 cm <sup>3</sup> )	Honda GX100 (98 cm <sup>3</sup> )
Compaction Area	3300 sqft (307 sqm)	3300 sqft (307 sqm)	3900 sqft (362 sqm)	3900 sqft (362 sqm)
Travel Speed	Up to 60 ft/min (18.3 m/min)	Up to 60 ft/min (18.3 m/min)	Up to 60 ft/min (18.3 m/min)	Up to 60 ft/min (18.3 m/min)
Compaction Depth*	Up to 24 in (61 cm)	Up to 24 in (61 cm)	Up to 24 in (61 cm)	Up to 24 in (61 cm)

\* Clean sand, optimum moisture. MBW recommends that lifts not exceed 12" of granular soil, 9" of cohesive soil.

All models: Percussion rate of up to 650 blow/min; Fuel capacity of 4.6 qt (4.3 l)

( ) Metric Measurements. Specifications subject to change without notice.

## RAMMER SPECIFICATIONS

- Published lift capacity reflects ideal conditions (clean sand, optimum moisture). Good compaction practice restricts lift depth to a maximum of 12 inches for granular soils, 6 to 9 inches for cohesive soils.
- Published travel speeds generally indicate operation under ideal conditions.

MBW urges interested parties to see

"Beware of Compactor Specifications" at [WWW.MBW.COM](http://WWW.MBW.COM)

- Area of compaction calculations factor in lift and travel expectations that may not be realistic for all conditions of compaction.
- There is no universally accepted formula or method for determining rammer "compaction force". Manufacturers employ their own formulas/methods to develop "compaction force" specifications thereby rendering comparison between rammers an exercise in futility.

- **1/8" Thick Polyethylene**  
fuel tank to resist punctures and abrasions and has largest capacity in the industry

- **Non-Metallic Spring Separator**  
to further reduce friction

- **4 Ply Vulcanized Rubber Bellows**  
reinforced with stranded steel cable

- **Compression Springs**  
manufactured of highest quality, stress relieved alloy steel. Springs do not bottom out or require rubber stoppers like competitive models

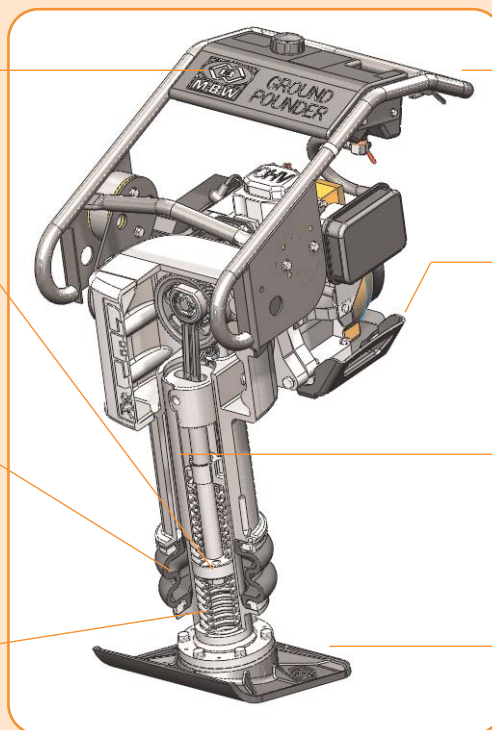

- **Precision Balanced Handle**  
with contoured fuel tank

- **Impact Resistant Engine Guard**  
protects against damage

- **High Density Non-Metallic Slide Bearings**  
reduce internal friction to the lowest levels in the industry

- **Ductile Cast Iron**  
MBW shoes do not absorb impact like competitive models but transfer all force to soil. R480 is available in both cast iron and aluminum

**HIGH PERFORMANCE PERCUSSION RAMMERS**

MBW approaches rammer development aggressively. We attack high maintenance issues usually associated with this product type. The MBW delivery system is the lowest friction, heat, and maintenance percussion unit in the industry. Less friction, heat, and wear in the delivery system translates into lower continuous horsepower demands to keep the rammer running. That means fewer engine problems and longer engine life. Bellows failures are reduced by as much as 90% with MBW's 4-ply, steel reinforced, vulcanized rubber bellows.



MBW addresses maintenance issues on throttle systems, tamping shoes, fuel tanks, gearboxes, shock mounts, proper engine rpm, and we answer the question as to when your service staff should perform routine maintenance.

While MBW rammers are decidedly high performance, the thing that truly separates our rammers from the competition is an unrelenting, aggressive attack on rammer problems.

**5 YEAR WARRANTY ON BELLOWS & PERCUSSION SYSTEM BEARINGS**

MBW works continuously to lower maintenance and extend life expectations of its rammers. We now introduce the industry's first percussion system completely free of high friction/heat/wear metal-on-metal reciprocating wear surfaces. The patented design features c-shaped, non-metallic, slide bearings between spring separator and spring box, ram shaft and spring box, and spring box and guide tube. Wear characteristics of the MBW bearings are several times better than traditional steel-on-cast iron designs. Lower operating friction/heat provide positive implications for engine, lubricant and bellows life. In the event percussion system lubricant is lost, MBW percussion systems are designed to fail a single slide bearing, locking up the system and prevent-



ing damage to other bearing surfaces, as well as bearings and seals in the rammer's gearbox. Because MBW percussion systems generate less internal friction, rammers operate more efficiently, consume less fuel, and deliver more compaction force for the purpose intended. When replacement is eventually called for, MBW slide bearings are replaced at low cost, returning percussion systems to original specification.

Endurance testing of the new design exceeded even MBW's expectations. As a result, MBW gas powered rammers now provide a 5 YEAR WARRANTY on percussion system slide bearings and bellows.



**MBW Inc.**  
 250 Hartford Road • P.O. Box 440  
 Slinger, Wisconsin • 53086-0440 • USA  
 Ph: 800-678-5237 or 262-644-5234 • Fax: 262-644-5169  
 E-mail: mbw@mbw.com • Website: www.mbw.com

**MBW UK Ltd.**  
 Units 2 & 3 Cochrane Street • Bolton BL3 6BN • England UK  
 Ph: 44 (0) 1204 387784 • Fax: 44 (0) 1204 387797  
 E-mail: mbwuk@btinternet.com • Website: www.mbw.com

**MBW FRANCE S.A.R.L.**  
 Z.A. d'Outreville • 5 rue Jean Baptiste Néron • 60540 BORNEL • France  
 Ph: 33 (0) 3 44 07 15 96 • Fax: 33 (0) 3 44 07 41 28  
 E-mail: mbwfrance@free.fr • Website: www.mbw.com

**AUTHORIZED DISTRIBUTOR**