

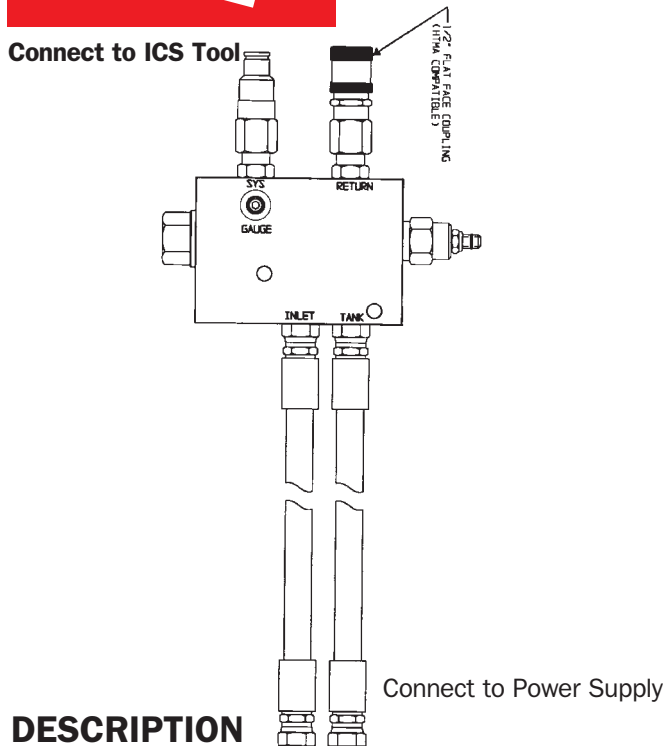

# HYDRAULIC FLOW ADAPTER VALVE



PRODUCT SPECIFICATIONS: HYDRAULIC FLOW ADAPTER VALVES		
FLOW OUTPUT	8 gpm (30 lpm)	12 gpm (45 lpm)
PRESSURE RELIEF	2500 psi (172.5 bar)	2500 psi (172.5 bar)
MANIFOLD SIZE	5" W x 3.5" L x 1.5" H (13 cm x 9 cm x 4 cm)	5.5" W x 5.5" L x 2.5" H (13.9 cm x 13.9 cm x 6.4 cm)
WEIGHT	11 lbs (5.5 kg)	11 lbs (5.5 kg)
PORT THREAD SIZE	Inlet & Tank SAE #10 (7/8-14 UNF) System & Return SAE #8 (3/4-16 UNF)	Inlet & Tank SAE #10 (7/8-14 UNF) System & Return SAE #8 (3/4-16 UNF)
HOSE THREAD SIZE	7/8-14 UNF	7/8-14 UNF
PART NUMBER	70350	71287

**Attention:** Hydraulic oil temperature should be monitored. Oil temperature above 150 F° (65 C°) can reduce hydraulic component life.

## DESCRIPTION

Leave the noise and fumes a comfortable distance away. The ICS® Hydraulic Flow Adapter Valve allows for smooth, quiet operation of any ICS Hydraulic Saw powered from other hydraulic equipment on the job-site such as a skid loader or backhoe. Use with high-capacity power supplies up to 20 gpm (76 lpm) and up to 2500 psi (172.5 bar). The flow rate from the adapter valve is fixed not to exceed the rating of your saw. Available for 8 gpm or 12 gpm (30 or 45 lpm) saws.

## INSTALLATION

1. Connect valve assembly to power supply (Fittings and bushings not provided):
  - A) Attach hose from port labeled INLET to the pressurized or pump line of power supply.
  - B) Attach hose from port labeled TANK to the tank return line of power supply.
2. Connect ICS tool hoses to flow adapter using flush-face hydraulic couplings.
3. Ensure proper rotational direction of ICS tool.

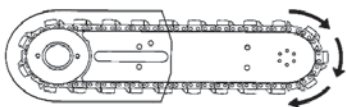

- If unsure about power supply flow ratings or cooling capacity, contact manufacturer of power supply.
- If limited space is available, the flush-couplings can be moved to auxiliary tool attachment ports.



## HYDRAULIC SCHEMATIC

