

HOLES TO BE CUTOUT
AS NEEDED TO
ACCEPT PART. NO.
3001 D-BOX SEAL

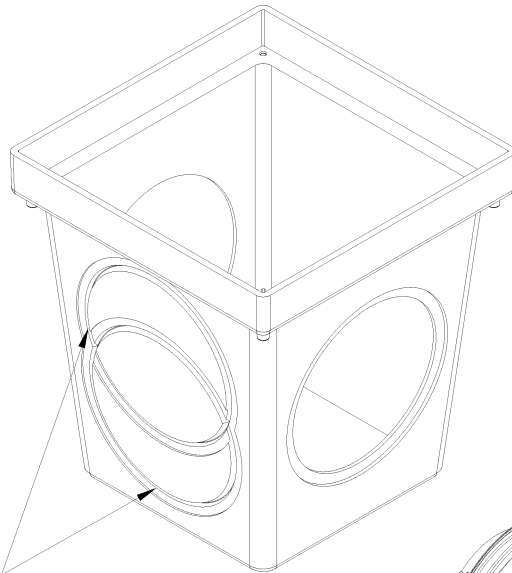

MODEL- PDB-9B
AS SHOWN WITH
2 SIDES WITH HOLES
2 SIDES WITH CUTOUTS

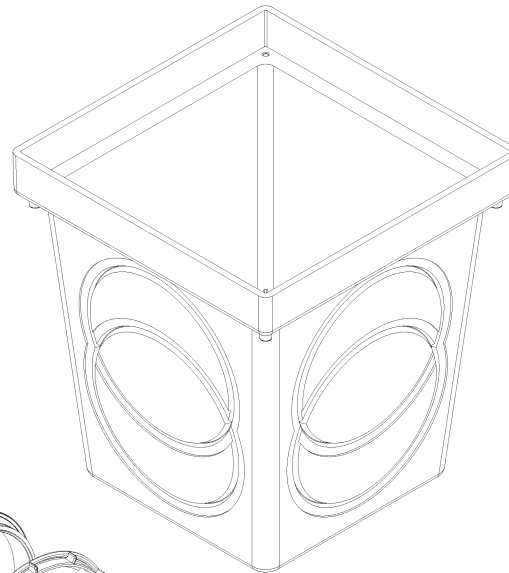

MODEL- PDB-9BL
AS SHOWN WITH
4 SIDES ALL CUTOUTS

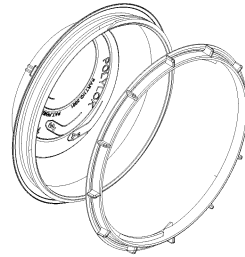

UNIVERSAL 9" DRAIN
BOX PART NO'S.
2- HOLE - PDB-9B
NO HOLE - PDB-9BL
GRATE - PDB-9G
MATERIAL - HDPE
COLOR - BLACK
GRATE:
32 SQ. IN. OPEN AREA
FLOW RATE - 41.92 GPM

