

DUFT- SQUARE CORNER FLOOR DRAIN

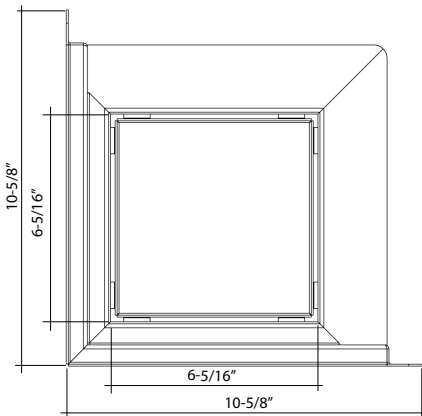

DUFT-S6

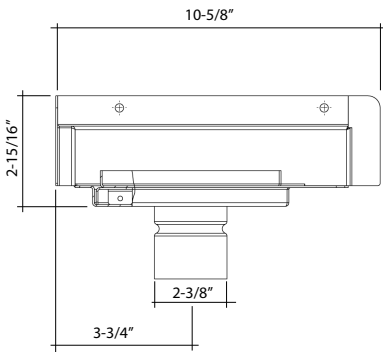
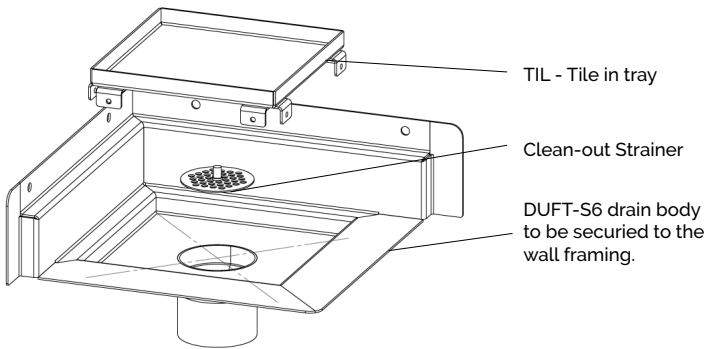

PROJECT: _____

NOTE: _____

NEO ANGLE CORNER DRAIN

DUFT Series is a one of a kind neo angle corner drain, that is a two-piece low profile floor drain system specifically designed for a truly invisible floor drain that is an easy installation and bonded waterproofing membrane. DUFT corner drain is designed to accommodate large, small format tiles or stone installations in a shower with a single plane slope to the drain. The DUFT corner drain is designed for commercial or residential projects and is intended for interior applications.

ADVANTAGES

- Single slope to drain
- Allows for the use of any size tile format tile
- Tile in grate available to match floor tile
- Made from heavy duty 304 stainless steel provides for long-lasting performance with passivated rust-proof finish

SUITABLE SUBSTRATES

- Concrete
- Exterior Glue Plywood (Interior Only)
- Cement Backer Board
- Cement Mortar Bed

PRODUCT ATTRIBUTES

- Application: Commercial and Residential
- Color/Finish Category: Stainless Steel
- Color/Finish Name: Passivated
- Diameter: 2 in
- Drain Opening: 2 in
- Fits Pipe Size: 2 in
- Material: Stainless Steel
- Material Type: AISI-304 SS (AISI-316 available upon request)
- Specifications - ASME: ASME A 112.18.2 (Pending)
- Specifications - CSA Certified: B 125.2 (Pending)
- Style Name: DUFT Series

MAINTENANCE

The DUFT drain system is made from durable, non-porous, hygienic, and rust-free stainless steel. Prior to cleaning, carefully remove the grate for either end of the drain using the extraction tool. Exposed surfaces of the DUFT drain System may be cleaned and maintained using mild soaps and a soft cloth. DO NOT use any abrasive cleaners, scrub pads or allow household cleaning agents, such as Bleach, to sit on the drain cover for an extended period. Prolong exposure to road salt, sea salt, or chlorine may have caused "surface" rust, which can be removed using Barkeepers Friend®, Soft Scrub® with Bleach, or Steel Brite®. Always follow the manufactures directions on the container. Follow proper maintenance procedures to prevent excessive surface rust. In areas of frequent exposure to salt, chlorine, and other chemical compounds, maintenance of the stainless grates should be performed at least 2-3 times per year.



ASME: A 112.18.2 (Pending)
CSA: B 125.2 (Pending)
PATENT PENDING DESIGN
US Patent Pending.
Canada Patent Pending.
EUIPO Patent Pending

Installer must verify all rough-in dimensions prior to installation and consult local and national codes. Adherence and compliance to local and national codes are the responsibility of the installer.

Data Sheets are subject to change without notice. For latest revision please contact Drains Unlimited, Inc.

10-YEAR LIMITED PRODUCT WARRANTY

COVERAGE AND CONDITIONS

Subject to the following conditions and limitations as specified hereinafter, Drains Unlimited[®] warrants that Drains Unlimited drain will be free from manufacturing defects, and will not rot, deteriorate or break down under normal utilization for a period of ten (10) years from the date of purchase only when the Product is used and installed in accordance with the terms and conditions of the Drains Unlimited[®] Floor Drains Product Data Sheet and industry standard guidelines that are not in conflict with the Data Sheet in effect at the time of installation. It is the responsibility of the owner/ builder/ installer to ensure the suitability of all building materials and all associated building materials for the owner's intended use. It is recommended that the owner consults with an experienced and professional installer.

RESOLUTION

If the Drains Unlimited Product fails to meet this warranty, then the owner's exclusive remedy and the sole obligation of Drains Unlimited -Systems, at its election, shall be to a) replace the failed Product or b) pay an amount not to exceed the original cost of the Product verified to be defective.

DISCLAIMER

There are no warranties beyond this expressed limited warranty as stated above. all other warranties, representations or conditions, expressed or implied, are disclaimed and excluded, including warranties, representations or conditions of merchantability or fitness for a particular purpose arising by statute or otherwise by law or from a course of dealing or usage of trade. Unlimited drain-systems excludes and in no event shall have any liability for lost profits or any other indirect, special, incidental, punitive, exemplary, or consequential damages, arising out of or otherwise connected to failure of the product or tile assembly of which it is part, nor misuse of the product or tile assembly, regardless of any strict liability, active or passive negligence of Drains Unlimited[®], and regardless of the legal theory (contract or tort or extra-contractual or other), nor from acts of war, terrorism, faulty and negligent penetration of the system, fires, explosions, acts of God, intentional acts of destruction or any losses due to structural failure or other causes unrelated to the product or delays, or any other incidental or consequential damages. This warranty is given in lieu of any other warranty expressed or implied. the remedies contained herein are the only remedies available for breach of this warranty. this limited warranty gives you specific legal rights; some states and provinces do not allow disclaimers or other restrictions of implied warranties, so some of the above disclaimers may not apply to you.

TRANSFERABILITY

This Limited Warranty extends ONLY to the original end user (defined as original intended owner and user of the property/unit in which the installation is incorporated - herein referred to as "Owner") and is not transferable or assignable, unless approved in writing by an Officer of Drains Unlimited Systems or otherwise prohibited by specific state or provincial law.

MODIFICATIONS TO WARRANTY

No modification or changes of any terms or conditions of this warranty are allowed except authorized by written agreement and signed by an Officer of Drains Unlimited.

CLAIMS ON THIS LIMITED WARRANTY

To make a claim under this Limited Warranty, the Owner must provide Drains Unlimited[®] in writing within 30 days of any alleged defect in the Product covered by this Limited Warranty, together with date and proof of purchase of the Product, proof of the costs of the original installation and name and address of all installers, failing which this Limited Warranty shall be of no legal effect. of Drains Unlimited[®] reserves the right at its election and as a condition of this Limited Warranty to inspect the alleged failure and defective condition



ASME: A 112.18.2 (Pending)
CSA: B 125.2 (Pending)
PATENT PENDING DESIGN
US Patent Pending.
Canada Patent Pending.
EUIPO Patent Pending

Installer must verify all rough-in dimensions prior to installation and consult local and national codes. Adherence and compliance to local and national codes are the responsibility of the installer.

Data Sheets are subject to change without notice. For latest revision please contact Drains Unlimited, Inc.