

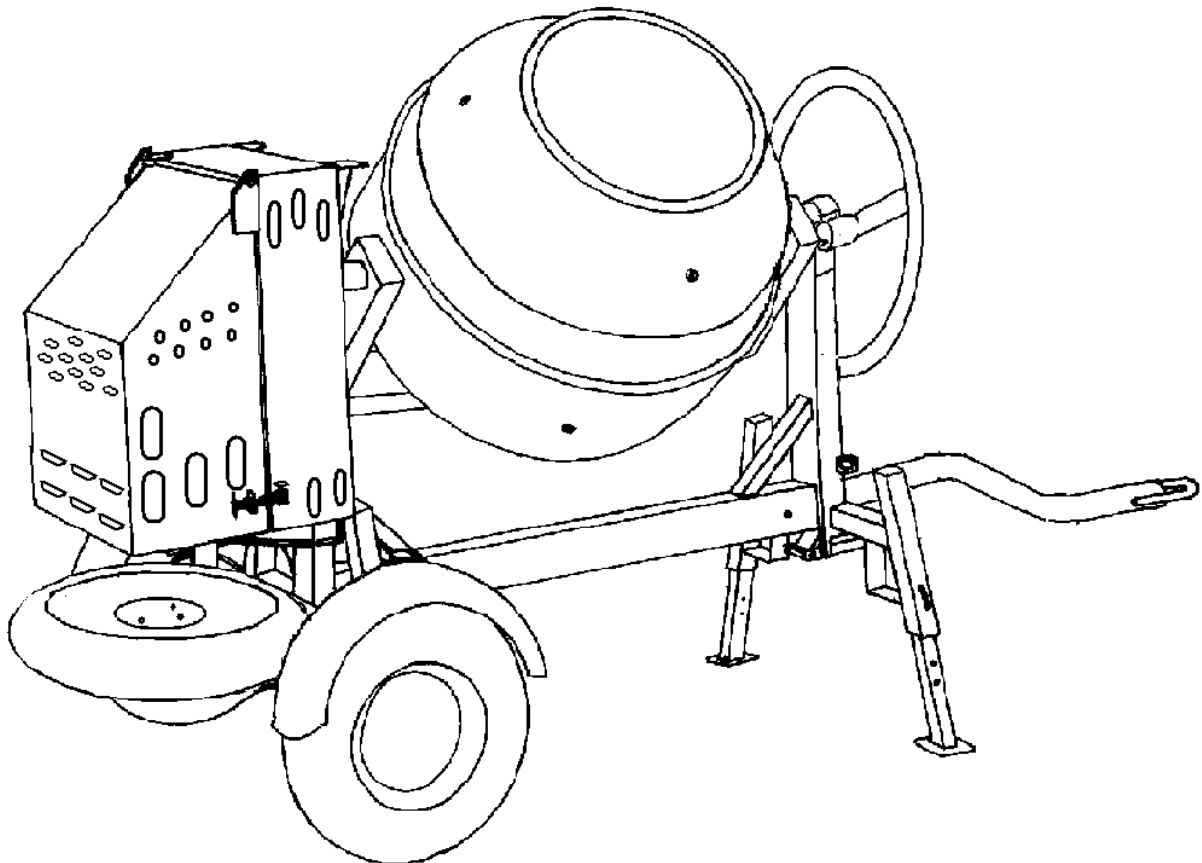

IMER *U.S.A. inc.*
WORKMAN II 250 MULTIMIXER

Model - 1105850

**MANUAL INSTRUCTION
and
PARTS LIST**



Manual Part. number 3209290_R04 - 2003/10

Machine serial N°

Write in the serial n° of your machine here

Thank-you for purchasing a Workman 250 II from an Imer U.S.A. dealer. **Your decision is an intelligent one.**

There is no other concrete mixer in the world which delivers the benefits and features of the Workman 250 II:

- Extremely rigid, mig welded bar steel frame.
- 5.5 H.P. Honda with low oil alert.
- Full width fenders.
- Torsion Bar suspension.
- Advance drum and paddle design, excellent mixing and discharge action.
- Telescopic foot stands which provide additional stability during operation.

At IMER U.S.A. we continually search for ways to better serve our customers. Should you have an idea or thought to share with us regarding this product we would appreciate hearing from you. Our motto is **"Tools and Services for the 21st Century"**. We look forward to delivering the goods.

Thank you again for your purchase.



Mace T. Coleman, Jr.
President, Imer U.S.A, Inc.

IMER WEST
207 Lawrence Avenue
So. San Francisco, CA 94080
Tel 650 - 872 - 2200
Fax 650 - 873 - 6482

IMER EAST
221 Westhampton Place
Capitol Heights, MD 20743
Tel 301 - 336 - 3700
Fax 301 - 336 - 6681

Table of Contents

IMER U.S.A., INC.
WORKMAN 250 II MULTIMIXER
INSTRUCTION MANUAL

NOTE: Please read this manual before beginning to assemble or operate this piece of equipment.

<i>ASSEMBLY</i>	<i>4</i>
<i>IMPORTANT NOTES AND ADVICE</i>	<i>5</i>
<i>OPERATING INSTRUCTIONS</i>	<i>7</i>
<i>MAINTENANCE.....</i>	<i>8</i>
<i>BASIC TROUBLE SHOOTING - TECHNICAL SPECIFICATIONS...</i>	<i>10</i>
<i>SPARE PARTS</i>	<i>11</i>

ASSEMBLY

+

TOWING

Essentially the Workman 250 II is fully assembled and ready to operate when it leaves the assembly facility here at Imer U.S.A. However, there are a couple items which should always be checked before towing the Workman 250 II.

1. Make sure each tire is inflated to 50 PSI (cold), and check the oil level of the Honda motor.
2. Make certain the retractable stability legs are raised up fully and locked in place with the anchor pin provided.
3. Make certain that the tow bar is properly anchored and its tow chain is in place. It is also important to loop the tow chain around the tow bar several times before connecting it to a vehicle.
4. Make sure the engine canopy door is latched shut.
5. Make certain that the hitch system on your car or truck is compatible to the tow bar tongue.
6. Finally, local laws and ordinances vary from state to state regarding the registration of towable construction equipment, check and see if a license plate is required. Call your local Department of Motor Vehicles for the proper procedure to follow.



NOTE

State law may also require a tail light assembly.

Check with your local Department of Motor Vehicles for the proper procedure to follow.



IMPORTANT NOTES AND ADVICE

Do's and Don'ts on the Safe Use of the Workman 250 II

In the interest of safety, whoever uses the Workman 250 II should first read this manual and become familiar with all of the important safety notes. Failure to follow this advice may result in injury to yourself and others.

WHAT TO DO !

- Carefully read and understand these instructions before operating the mixer. Read the Honda manual too.
- Always turn off the engine and disconnect the spark plug wire before cleaning or maintaining the mixer. Mixers powered by electric motors should be unplugged from their power source before servicing is performed.
- Make sure the safety guards are always in place.
- When using the machine always wear safety boots with reinforced toe-caps, safety glasses, gloves, hard hat, and clothing with the appropriate fit. Loose clothing can cause injury should it become entangled with the mixer.
- Practice starting and stopping the machine.
- Keep the mixer clean and free of debris build-up.
- Periodically inspect your mixer for abnormal wear or damage.
- Always stop the engine before adding fuel.
- Do not operate the mixer while under the influence of drugs or alcohol.
- Always operate the mixer on a level surface
- When loading the Workman it is the best to pour your bagged material into a 5 gallon bucket then pour it into the drum
- It is much easier on your body and safer to load the drum in this manner.



IMPORTANT NOTES AND ADVICE **WHAT NOT TO DO !**

DO NOT

Place your hands or any other object inside the mixer drum while it is running.

DO NOT

Place any tools or other objects in or around the mixer drum while it is running .

DO NOT

Operate the mixer on a surface that is UNEVEN.... if the Workman is placed on an incline, it can fall over or roll away.

DO NOT

Clean, assemble or work on the mixer while it is plugged in !

DO NOT

Operate the mixer in or around water puddles !

DO NOT

Leave the mixer unattended !

DO NOT

Allow other persons around the mixer while it is operating

DO NOT

Operate the Workman II 250 if you are uncertain as to how to run the machine.... Contact your local Imer Distributor or call Imer U.S.A. at 800 - 275 - 5463.

DO NOT

Operate the mixer while under the influence of drugs or alcohol !

***WE WANT SAFE AND EFFICIENT
PRODUCTION/OPERATION
FOR ALL OUR CUSTOMERS !***

OPERATING INSTRUCTIONS

1. Before starting the engine read the Honda manual provided and become familiar with the GX160 powerplant. Especially important is to check the oil daily and change it monthly. Additionally, cleaning the air filter weekly ensures consistently good performance.
2. Operate the the Workman II 250 on a level surface. For additional stability the telescopic foot stands can be lowered and locked into place.
3. To put the drum in the loading position rotate the dump wheel until the desired drum position is achieved.
4. Start the engine and set the throttle at 3/4 to full on.
5. Now add 1/2 of the water which will be required and then begin to add the cement and aggregates. Additional water can be added as the cement and aggregates mix together.



BE CAREFUL ! Do Not put your shovel or your hands inside the drum !

6. To put the drum in the discharge position rotate the dump wheel until the desired drum position is achieved.
7. During the loading, mixing, and discharge cycle it is important to keep the mixer running at all times.
8. Always prepare your work site to have a level ground surface, the mixer must be stable as you load and discharge the drum.

MAINTENANCE

Lubrication

1. All the other components on the mixer which engage or move back and forth should be lubricated with a light aerosol type lubricant on a weekly basis. WD- 40 works well for this application.
2. Essentially the gearbox is sealed for life. The quality of the gears and the lubricant are such that changing the oil is not necessary. If you want to change the oil, see your dealer or call IMER U.S.A directly for instruction.
3. One a year remove the cast cap from the top half of the dump gear assembly and grease it up good.
(Part #36, page 12)

Belt Tension

1. The mixer has two belts: one in the canopy and the other in the arm. The belts are properly adjusted before leaving our factory, however, it is a good idea to check their tension before operating the mixer. Then, when one belt becomes loose, tighten it back to this original condition.



NOTE

The belts will stretch the most during the first few hours of operation check them frequently, and always kill the motor and disconnect the spark plug wire before touching the belts. Or, if your machine has an electric motor, unplug it from the power source before adjusting the belts.

2. To tighten the belt inside the canopy loosen the bolts which anchor the motor mount plate to the mixer frame. This allows the motor mount plate to slide down the frame, which in turn tightens the belt. The belt should have 1/4" to 3/8" of play. Now re-tighten the bolts which anchor the motor mount plate.
3. To tighten the belt inside the arm loosen the 4 nuts which anchor the gearbox on the arm. Tighten the belt by turning the adjustment bolt. The belt should have 1/4" to 3/8" of play, do not over tighten as this shortens their drive life. Now re-tighten the gearbox anchor bolts.



NOTE

It is very important to keep the engine pulley and the drive pulley in line with one another. Failure to maintain this alignment will cause the belt to twist and then break.



MISC.

Every month check all the mixer's mounting hardware to ensure all the nuts and bolts are properly tightened.

Wheel Bearings

1. The wheel bearings should be cleaned and repacked every 6 months to 1 year. The interval being dependant upon the amount of time the machine is towed, and under what conditions. This maintenance procedure is the same as that for automotive wheel bearings.

Engine

Read the Honda manual carefully ... and follow their instructions.

Changing the oil and cleaning the air filter frequently ensure a reliable and long lasting motor.

When you may need Honda Engine Service or Warranty Assistance, take the machine to your local Honda power equipment dealer, they will honor the Warranty throughout America.



NOTE

It is always a good idea to check the oil level in the engine crankcase at the start of each working day. Clean oil at the correct level makes for a engine that will last and last.

Mixer's drum disassembly and re-assembly

In case it's necessary to remove the drum, to reset it it's necessary.

- to clean carefully the gear shaft cone and the drum cone.
- to place the drum on the shaft cone, making sure that shaft shear pin is inside its seat in the drum cone.
- to block drum tightening screw with washer by following tightening torques:

Workman 250 II: 220 ± 20 Nm.



TECHNICAL SPECIFICATIONS **WORKMAN II 250**

Drum capacity	9 CU. FT.
Batch Output	6 CU. FT. (1 bag)*
Drum Diameter	27.5 Inches
Discharge Outlet Height	27.5 Inches
Pneumatic Wheels	4.50-10 Inches (50 PSI)
Power plants	5.5 HP Honda GX160 1.5 HP electric
Overall Operating Dimensions	76" x 49" x 57"
Overall Storage Dimensions	76" x 49" x 57"
Weight	450 LBS (206 Kg)

*Capacity based upon usable volume

***Due to Imer U.S.A. 's commitment to
Research and Development,
specifications are subject
to change without notice.***



SPARE PARTS

DRAWING 1.3 (WORKMAN II 250 CONCRETE MIXER - 1105850)

Ref.	P.n.	Main Description	NOTES
1	3209287	MAIN FRAME	
2	3209294	TOW BAR	
3	3208906	ARM	
4	3208811	DRUM ASS'Y	
5	3206690	T-BOLT	
6	3207225	T-BOLT WASHER	
7	3209953	STABILIZING FOOT	
8	3208792	NYLON FIBER BUSHING	
9	2227205	CIRCLIP	E 50
10	3209032	PLASTIC PLUG	
11	3209298	HONDA MOTOR	HONDA G 150
12	3209052	MOTOR PULLEY	
13	3206322	WASHER	8X30X5
14	2210950	MOTOR BELT	
15	3209524	BELT GUARD	
16	2248216	TORSION BAR AXLE	
17	3209293	LEG FRAME	
18	3209250	REAR LEG FRAME	
19	3208924	GEAR BOX	
20	2223980	WHEEL NUT	S 190 TT
21	2223923	SELF LOCKING NUT	M 8 Z
22	2222114	BOLT	M8X90 Z
23	2227320	CIRCLIP	E 20
24	3208925	GEAR BOX BELT COVER	
25	2222420	BOLT	4.8X13
26	3209134	BOLT	M10X140Z
27	3208776	KEY WAY	14X9X25
28	3208770	BUSHING	
29	3208773	DUMP GEAR	Z 32
30	2211407	TIRE + WHEEL	
31	3206704	ANCHOR PIN	
32	3208944	BUMPER PAD	
33	3208790	BUMPER PAD	
34	2224220	WASHER	D10X40
35	2223920	SELF LOCKING NUT	M10 Z
36	3213876	CAST CAP	
37	2222181	BOLT	
38	2223921	SELF LOCKING NUT	
39	3209786	DUMP GEAR CASTING	
40	2229300	KEY WAY	6X6X20
41	2224204	WASHER	D 8X24
42	3205545	RUBBER SWITCH CUP	E 20
43	3208777	DUMP WHEEL	
44	3206748	DUMP HANDEL	
45	2223923	SELF LOCKING NUT	M8 Z
46	2222077	BOLT	M8X20 Z
47	3209049	BELT - GEAR BOX DRIVE	530 J6
48	3209289	SAFETY LABEL	S 190 TT
49	3208916	ROLLER SHAFT	
51	3203917	WASHER	D8X25X4 Z
52	3201015	LEG CAP	
53	3209467	ANCHOR PIN	
54	2226700	SPLIT PIN	
55	3210560	ENGINE MOUNTING FRAME	
56	3209119	ENGINE MOUNTING PLATE	
57	2222148	BOLT	M10X65 Z
58	3208915	ROLLER GUIDE	
59	2204421	ROLLER BEARING	6201 2RS
60	1227330	CIRCLIP	E 15
61	2204438	DRIVE SHAFT BEARINGS	6004 2RS
62	3208919	GEAR BOX DRIVE PULLEY	
63	3209055	SPACER	
64	3203117	KEY WAY	5X5X20
65	3209054	SHAFT	
67	3209053	ENGINE PULLEY	
68	3208935	CANOPY DOOR	
69	3209459	CANOPY REAR	
70	3209120	MOUNTING BRACKET	
71	2221994	PULLEY BOLT	5/16"X25 Z
72	3209136	ENGINE PULLEY GUARD	
73	3209111	LOCK LEVER ROD	
74	2222190	BOLT	M8X40 Z
77	3209133	DUMP ARM PLUG	
78	2222091	BOLT	M8X70 Z
79	3205544	KILL BUTTON	
80	3206011	FENDER	
81	2222146	BOLT	
82	3207782	FENDER ARM	
83	2222060	BOLT	M8X20 Z
84	2235452	PLUG	
85	3206855	BOLT	
87	3206861	AXLE MOUNTING SPACER	
88	2223929	NUT	
89	2234861	TOW CHAIN	
90	2292298	QUICK CLIP	
91	3208921	SHORT SPACER	
92	3208923	LONG SPACER	

DRAWING 1.3 WORKMAN II 250 CONCRETE MIXER

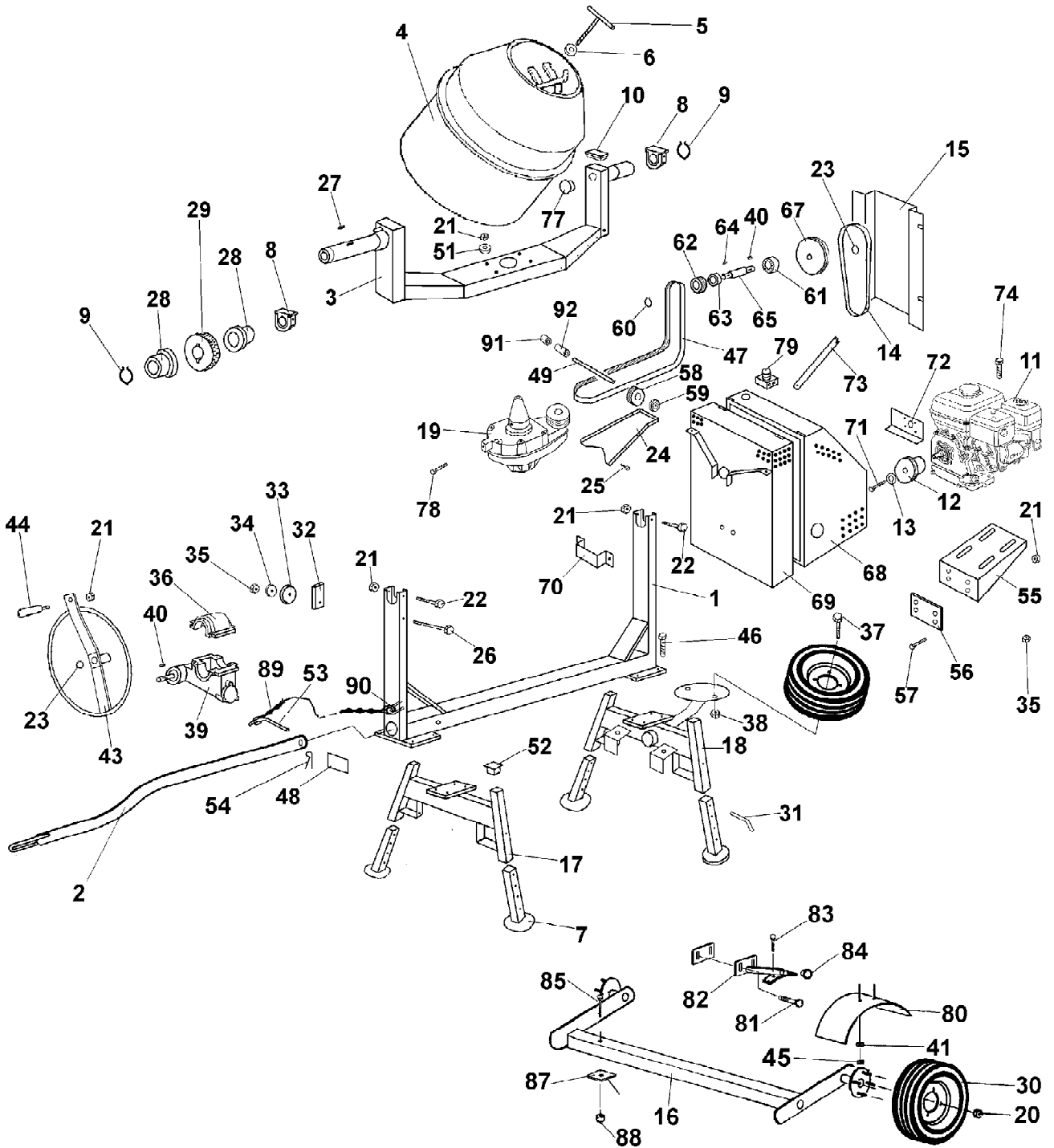



TABLE 2 - GEAR BOX : WORKAM II 250 (COD. 3208746)

RIF.	COD.	GB	NOTE
1	2222018	BOLT	M8 X 35 Z
2	3213896	OIL SEAL	72X52X8
3	2222112	BOLT	M8 X 100 Z
4	3209681	GEAR BOX CASE	
5	3213887	GEAR BOX GASKET	
6	2228360	SHEAR PIN	8 X 16
7	3213897	KEY WAY	10X8X15
8	3209679	BEARING	6301
9	2202493	GEAR WHEEL	Z.79
10	2229249	KEY	5X5X12
11	3208754	PINION GEAR	Z9 M 1,75
12	3209680	GEAR BOX CASE	
13	3200094	OIL SEAL	35X20X7
14	2229250	KEY	5X5X15
15	2204440	BEARING	6004
16	3209770	PINION GEAR	Z9 M 1,25
17	2222114	BOLT	M8 X 90 Z
18	3208762	PULLEY	
19	3208752	SPACER	
20	2223570	NUT	M8 Z
21	2224140	WASHER	D=8 Z
22	3213899	BEARING	6209 SKF
23	2227220	CIRCLIP	E 40
24	3208756	GEAR	Z68
25	3213898	BEARING	6207 SKF
26	2228820	LOCATING PIN	D=6X14
27	3208748	DRIVE SHAFT	
28	1227330	CIRCLIP	E 15
29	2224060	WASHER	D=8 Z

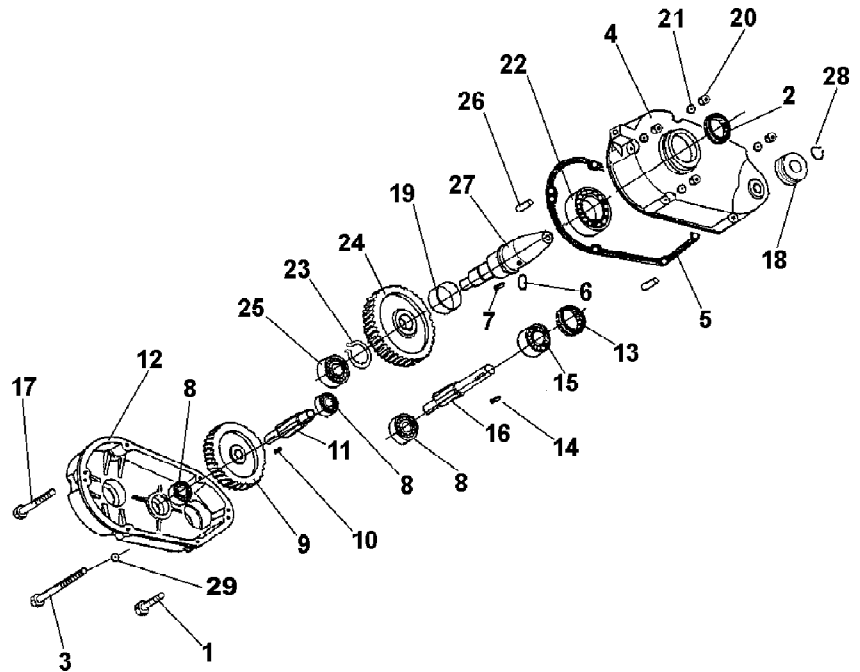
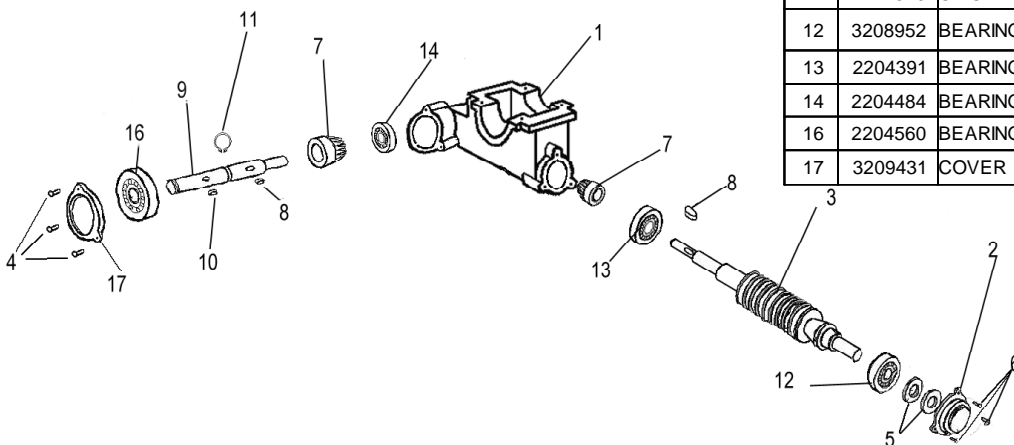

TABLE 3 - DRUM REDUCTION UNIT

RIF.	COD.	DESCRIPTION	NOTE
1	3209428	GEAR BOX CASE	
2	3209430	COVER	
3	3213893	DUMP GEAR	M10X110 Z
4	2222465	BOLT	M5X15 Z
5	3213811	OIL SEAL RING	47X17X7
6	3209728	SCREW	M6X15
7	3213264	PINION GEAR	Z 20
8	2229259	KEY WAY	6X6X14
9	3208771	SHAFT	
10	2229300	KEY WAY	6X6X20
11	2227320	CIRCLIP	E 20
12	3208952	BEARING	6206 2Z
13	2204391	BEARING	6205 2Z
14	2204484	BEARING	6203 2Z
16	2204560	BEARING	6204 2RS
17	3209431	COVER	





EQUIPMENT WARRANTY

IMER U.S.A. INC.

207 Lawrence avenue
So. San Francisco, CA 94080
Tel.(650) 872-2200
Fax(650) 873-6482

We warrant to the original purchaser that the IMER equipment described herein (the "equipment") shall be free from defects in material and workmanship under normal use and service for which it was intended for period of one (1) year from the date of purchase by the original purchaser.

Our obligation under this warranty is expressly limited to replacing or repairing, free of charge, F. O.B. our designated service facility, such part of the equipment as our inspection shall disclose to be defective. Parts such as engines, motors, pumps, valves, electric motors, etc. furnished by us, but not manufactured by us, will carry only the warranty of the manufacturer. Transportation charges or duties shall be borne by purchaser. This shall be the limit of our liability with respect to the quality of the equipment.

This warranty shall not apply to any equipment, or parts thereof, which has been damaged by reason of accident, negligence, unreasonable use, faulty repairs, or which has not been maintained and operated in accordance with our printed instructions for the equipment. Further, this warranty is void if the equipment, or any of its components, is altered or modified in any way.

THIS WARRANTY IS EXPRESSLY IN LIEU OF ALL OTHER WARRANTIES, EXPRESSED OR IMPLIED, INCLUDING ANY IMPLIED WARRANTY OF MERCHANTABILITY OR FITNESS FOR A PARTICULAR PURPOSE.

We make no other warranty, representation or guarantee, nor is anyone authorized to make one on our behalf. We shall not be liable for consequential damage of any kind, including loss or damage resulting, directly or indirectly, from the use or loss of use of the machine. Without limiting the generality of the foregoing, this exclusion from liability embraces the purchaser's expenses for downtime, damages for which the purchaser may be liable to other person, damages to property, and injury or death of any persons.

This warranty shall not be deemed to cover maintenance parts, including but not limited to blades, belts, hoses, hydraulic oil, or filters, for which we shall have no responsibility or liability whatsoever.



IMER *U.S.A. inc.*

WORKMAN 350 II MULTIMIXER

Model 1105855

MANUAL INSTRUCTION and PARTS LIST

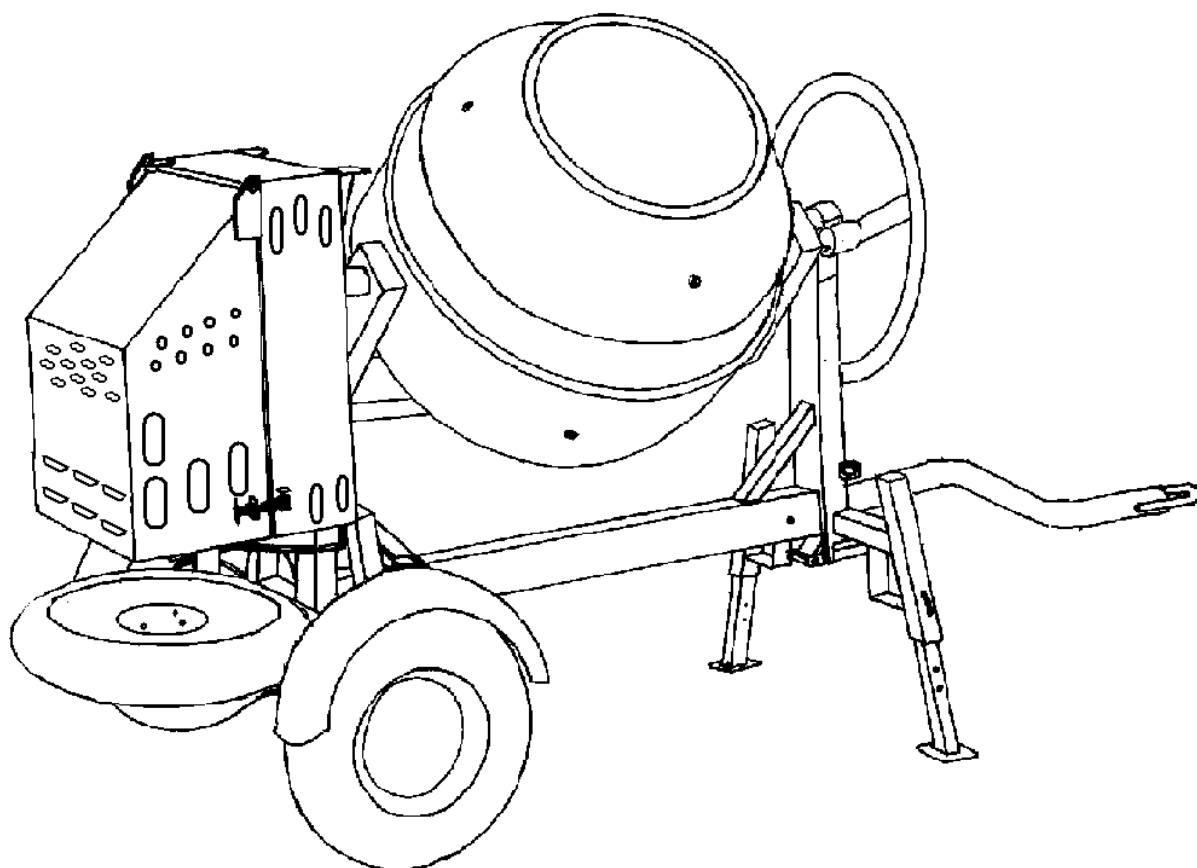

Manual Part. number 3209281_R05 - 2005/03

Machine serial N°

Write in the serial n° of yuor machine here

Thank-you for purchasing a Workman 350 II from an Imer U.S.A. dealer. **Your decision is an intelligent one.**

There is no other concrete mixer in the world which delivers the benefits and features of the Workman 350 II.

- Extremely rigid, mig welded bar steel frame.
- 5.5 H.P. Honda with low oil alert.
- Full width fenders.
- Torsion Bar suspension.
- Advance drum and paddle design, excellent mixing and discharge action.
- Telescopic foot stands which provide additional stability during operation.

At Imer U.S.A. we continually search for ways to better serve our customers. Should you have an idea or thought to share with us regarding this product we would appreciate hearing from you. Our motto is **"Tools and Services for the 21st Century"**. We look forward to delivering the goods.

Thank you again for your purchase.



Mace T. Coleman, Jr.
President, Imer U.S.A., Inc.

IMER USA WEST
3654 Enterprise Avenue
Hayward, CA 94545
Toll Free: (800) 275-5463
Office: (510) 670-7970
Fax: (510) 783-4255

IMER USA EAST
221 Westhampton Place
Capitol Heights, MD 20743
Tel: 301 - 336 - 3700
Fax: 301 - 336 - 6687

Table of Contents

IMER U.S.A., INC.
WORKMAN 350 II MULTIMIXER
INSTRUCTION MANUAL

NOTE: Please read this manual before beginning to assemble or operate this piece of equipment.

ASSEMBLY 4

IMPORTANT NOTES AND ADVICE 5

OPERATING INSTRUCTIONS 7

MAINTENANCE..... 8

BASIC TROUBLE SHOOTING - TECHNICAL SPECIFICATIONS... 10

SPARE PARTS 11

ASSEMBLY

+

TOWING

Essentially the Workman 350 II is fully assembled and ready to operate when it leaves the assembly facility here at Imer U.S.A. However, there are a couple items which should always be checked before towing the Workman 350 II.

1. Make sure each tire is inflated to 50 PSI (cold), and check the oil level of the Honda motor.
2. Make certain the retractable stability legs are raised up fully and locked in place with the anchor pin provided.
3. Make certain that the tow bar is properly anchored and its tow chain is in place. It is also important to loop the tow chain around the tow bar several times before connecting it to a vehicle.
4. Make sure the engine canopy door is latched shut.
5. Make certain that the hitch system on your car or truck is compatible to the tow bar tongue.
6. Finally, local laws and ordinances vary from state to state regarding the registration of towable construction equipment, check and see if a license plate is required. Call your local Department of Motor Vehicles for the proper procedure to follow.



NOTE

State law may also require a tail light assembly.

Check with your local Department of Motor Vehicles for the proper procedure to follow.

IMPORTANT NOTES AND ADVICE

Do's and Don'ts on the Safe Use of the Workman 350 II

In the interest of safety, whoever uses the Workman 350 II should first read this manual and become familiar with all of the important safety notes. Failure to follow this advice may result in injury to yourself and others.

WHAT TO DO !

- Carefully read and understand these instructions before operating the mixer. Read the Honda manual too.
- Always turn off the engine and disconnect the spark plug wire before cleaning or maintaining the mixer. Mixers powered by electric motors should be unplugged from their power source before servicing is performed.
- Make sure the safety guards are always in place.
- When using the machine always wear safety boots with reinforced toe-caps, safety glasses, gloves, hard hat, and clothing with the appropriate fit. Loose clothing can cause injury should it become entangled with the mixer.
- Practice starting and stopping the machine.
- Keep the mixer clean and free of debris build-up.
- Periodically inspect your mixer for abnormal wear or damage.
- Always stop the engine before adding fuel.
- Do not operate the mixer while under the influence of drugs or alcohol.
- Always operate the mixer on a level surface.
- When loading the Workman it is the best to pour your bagged material into a 5 gallon bucket then pour it into the drum.
- It is much easier on your body and safer too to load the drum in this manner.

IMPORTANT NOTES AND ADVICE **WHAT NOT TO DO !**

DO NOT

Place your hands or any other object inside the mixer drum while it is running.

DO NOT

Place any tools or other objects in or around the mixer drum while it is running .

DO NOT

Operate the mixer on a surface that is UNEVEN.... if the Workman is placed on an incline, it can fall over or roll away.

DO NOT

Clean, assemble or work on the mixer while it is plugged in !

DO NOT

Operate the mixer in or around water puddles !

DO NOT

Leave the mixer unattended !

DO NOT

Allow other persons around the mixer while it is operating

DO NOT

Operate the Workman II 350 if you are uncertain as to how to run the machine.... Contact your local Imer Distributor or call Imer U.S.A. at (800) 275-5463

DO NOT

Operate the mixer while under the influence of drugs or alcohol !

***WE WANT SAFE AND EFFICIENT
PRODUCTION/OPERATION
FOR ALL OUR CUSTOMERS !***

OPERATING INSTRUCTIONS

1. Before starting the engine read the Honda manual provided and become familiar with the GX160 powerplant. Especially important is to check the oil level daily and change it monthly. Additionally, cleaning the air filter weekly ensures consistently good performance.
2. Operate the the Workman II 350 on a level surface. For additional stability the telescopic foot stands can be lowered and locked into place.
3. To put the drum in the loading position rotate the dump wheel until the desired drum position is achieved.
4. Start the engine and set the throttle at 3/4 to full on.
5. Now add 1/2 of the water which will be required and then begin to add the cement and aggregates. Additional water can be added as the cement and aggregates mix together.



BE CAREFUL ! Do Not put your shovel or your hands inside the drum !

6. To put the drum in the discharge position rotate the dump wheel until the desired drum position is achieved.
7. During the loading, mixing, and discharge cycle it is important to keep the mixer running at all times.
8. Always prepare your work site to have a level ground surface, the Mixer must be stable as you load and discharge the drum.

MAINTENANCE

Lubrication

1. All the other components on the mixer which engage or move back and forth should be lubricated with a light aerosol type lubricant on a weekly basis. WD- 40 works well for this application.
2. Essentially the gearbox is sealed for life. The quality of the gears and the lubricant are such that changing the oil is not necessary. If you want to change the oil, see your dealer or call IMER U.S.A directly for instruction.
3. One a year remove the cast cap from the top half of the dump gear assembly and grease it up good.
(Part # 36, page 12)

Belt Tension

1. The mixer has two belts: one in the canopy and the other in the arm. The belts are properly adjusted before leaving our factory, however, it is a good idea to check their tension before operating the mixer. Then, when one belt becomes loose, tighten it back to this original condition.



NOTE

The belts will stretch the most during the first few hours of operation check them frequently, and always kill the motor and disconnect the spark plug wire before touching the belts. Or, if your machine has an electric motor, unplug it from the power source before adjusting the belts.

2. To tighten the belt inside the canopy loosen the bolts which anchor the motor mount plate to the mixer frame. This allows the motor mount plate to slide down the frame, which in turn tightens the belt. The belt should have 1/4" to 3/8" of play. Now re-tighten the bolts which anchor the motor mount plate.
3. To tighten the belt inside the arm loosen the 4 nuts which anchor the gearbox on the arm. Tighten the belt by turning the adjustment bolt. The belt should have 1/4" to 3/8" of play, do not over tighten as this shortens their drive life. Now re-tighten the gearbox anchor bolts.



NOTE

It is very important to keep the engine pulley and the drive pulley in line with one another. Failure to maintain this alignment will cause the belt to twist and then break.



MISC.

Every month check all the mixer's mounting hardware to ensure all the nuts and bolts are properly tightened.

Wheel Bearings

1. The wheel bearings should be cleaned and repacked every 6 months to 1 year. The interval being dependant upon the amount of time the machine is towed, and under what conditions. This maintenance procedure is the same as that for automotive wheel bearings.

Engine

Read the Honda manual carefully ... and follow their instructions.

Changing the oil and cleaning the air filter frequently ensure a reliable and long lasting motor.

When you may need Honda Engine Service or Warranty Assistance, take the machine to your local Honda power equipment dealer, they will honor the warranty throughout America.



NOTE

It is always a good idea to check the oil level in the engine crankcase at the start of each working day. Clean oil at the correct level makes for a engine that will last and last.

Mixer's drum disassembly and re-assembly

In case it's necessary to remove the drum, to reset it it's necessary.

- to clean carefully the gear shaft cone and the drum cone.
- to place the drum on the shaft cone, making sure that shaft shear pin is inside its seat in the drum cone.
- to block drum tightening screw with washer by following tightening torques:

Workman 350 II: 300 ± 20 Nm.

TECHNICAL SPECIFICATIONS

WORKMAN II 350

Drum capacity	12.5 CU. FT.
Batch Output	9.5 CU. FT. (1.5 bag)* 1/3 of a cubic yard
Drum Diameter	32.5 Inches
Discharge Outlet Height	26.5 Inches
Pneumatic Wheels	4.50-10 Inches (50 PSI)
Power plants	5.5 HP Honda GX160 2.0 HP electric
Overall Operating Dimensions	79" x 50" x 66"
Overall Storage Dimensions	79" x 50" x 66"
Weight	545 LBS (248 Kg)

*Capacity based upon usable volume

***Due to Imer U.S.A. 's commitment to
Research and Development,
specifications are subject
to change without notice.***



SPARE PARTS

DRAWING 1.3 (WORKMAN II 350 CONCRETE MIXER - 1105855)			
Ref.	P.n.	Main Description	NOTES
1	3209275	MAIN FRAME	
2	3209277	TOW BAR	
3	3209183	ARM	
4	3206635	DRUM ASSY	
5	3210467	T-BOLT	
6	3210466	T-BOLT WASHER	
7	3209954	STABILIZING FOOT	
8	3209009	NYLON FIBER BUSHING	
9	2227205	CIRCLIP	E 50
10	3209032	PLASTIC PLUG	
11	3209298	HONDA MOTOR	GX 160 KI
12	3209165	MOTOR PULLEY	
13	2224190	WASHER	8X30X5
14	2210950	MOTOR BELT	
15	3209121	BELT GUARD	
16	2248216	TORSION BAR AXLE	
17	3209279	LEG FRAME	
18	3209274	REAR LEG FRAME	
19	3210476	GEAR BOX	
20	2223980	WHEEL NUT	
21	2223920	SELF LOCKING NUT	M 10
22	1222694	BOLT	M10X110 Z
23	2227320	CIRCLIP	E 20
24	3209091	GEAR BOX BELT COVER	
25	2222420	BOLT	4,8X13
26	3210606	BOLT	M10X160Z
27	3208776	KEY WAY	14X9X25
28	3208770	BUSHING	
29	3208773	DUMP GEAR	Z 32
30	2211407	TIRE+ WHEEL	
31	3206704	ANCHOR PIN	
32	3208789	BUMPER PAD	
33	3208790	BUMPER PAD	
34	2224220	WASHER	D10X40
35	2223923	SELF LOCKING NUT	M8 Z
36	3213876	CAST CAP	
37	2222181	BOLT	
38	2223921	SELF LOCKING NUT	
39	3209786	DUMP GEAR CASTING	
40	2229300	KEY WAY	6X6X20
41	2224204	WASHER	D8X24
43	3208777	DUMP WHEEL	
44	3206748	DUMP HANDEL	
45	2223923	SELF LOCKING NUT	M8 Z
46	2222056	BOLT	M10X25 Z
47	3209081	BELT - GEAR BOX DRIVE	580 J6
48	3209280	SAFETY LABEL	
49	3208916	ROLLER SHAFT	
51	3209178	WASHER	D10X30X4 Z
52	2257706	LEG CAP	
53	3209468	ANCHOR PIN	
54	2226700	SPLIT PIN	
55	3210560	ENGINE MOUNTING FRAME	
56	3209193	ENGINE MOUNTING PLATE	
57	2222145	BOLT	M10X80 Z
58	3208915	ROLLER GUIDE	
59	2204421	ROLLER BEARING	6201 2RS
60	1227330	CIRCLIP	E 15
61	2204438	DRIVE SHAFT BEARINGS	6004 2RS
62	3208919	GEAR BOX DRIVE PULLEY	
63	3209055	SPACER	
64	3203117	KEY WAY	5X5X20
65	3209074	SHAFT	
67	3209053	ENGINE PULLEY	
68	3208935	CANOPY DOOR	
69	3209520	CANOPY REAR	
70	3209196	MOUNTING BRACKET	
71	2221994	PULLEY BOLT	5/16"X25 Z
72	3209136	ENGINE PULLEY GUARD	
73	3209111	LOCK LEVER ROD	
74	2222190	BOLT	M8X40 Z
77	3209195	DUMP ARM PLUG	
78	2222091	BOLT	M8X70 Z
79	3205544	KILL BUTTON	
80	3206011	FENDER	
81	2222146	BOLT	
82	3207782	FENDER ARM	
83	2222060	BOLT	
84	2235452	PLUG	
85	3206855	BOLT	
87	3206861	AXLE MOUNTING SPACER	
88	2223929	NUT	
89	2234861	TOW CHAIN	
90	2292298	QUICK CLIP	LATC

DRAWING 1.3 WORKMAN II 350 CONCRETE MIXER

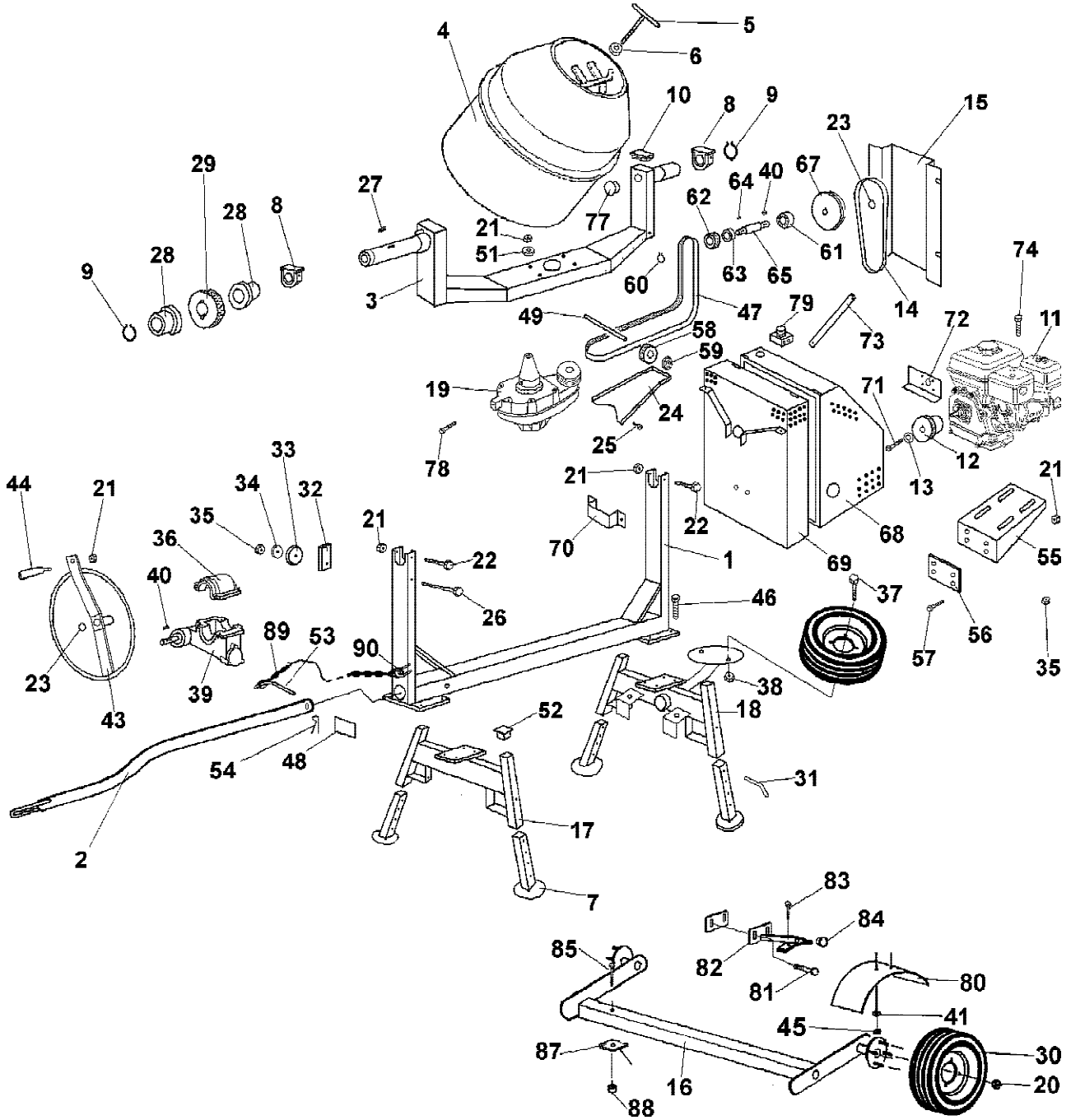
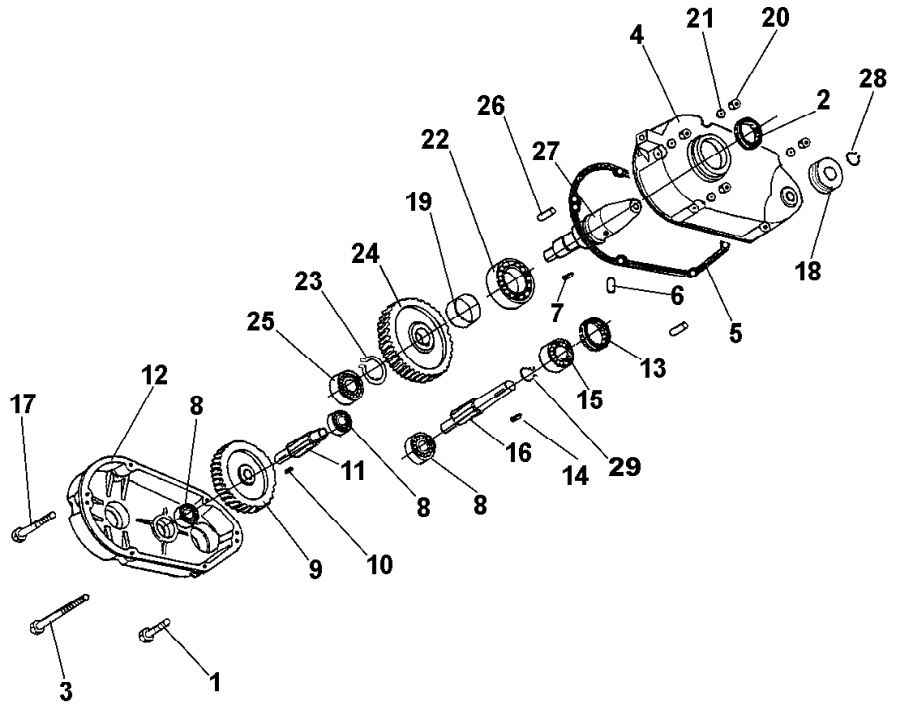
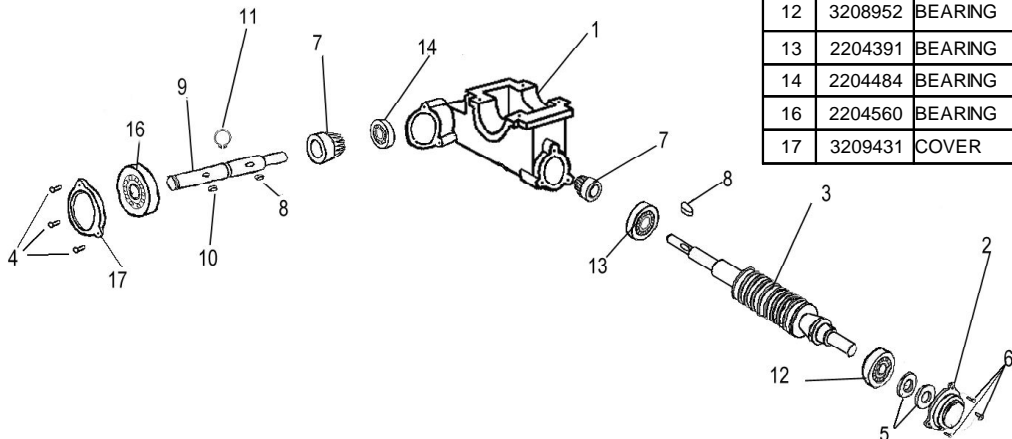

TABLE 2 - GEAR BOX - WORKMAN II 350 (COD. 3210476)			
RIF.	COD.	GB	NOTE
1	2222148	BOLT	M10X65 Z
2	3213179	OIL SEAL	90X65X10
3	2222153	BOLT	M10X100 Z
4	3209515	GEAR BOX CASE	
5	3209811	GEAR BOX GASKET	
6	3213177	SHEAR PIN	
7	3213178	KEY WAY	10X8X20
8	3209682	BEARING	6302
9	3209801	GEAR WHEEL	Z.79
10	2229259	KEY	6X6X14
11	3208975	PINION GEAR	Z 11
12	3209514	GEAR BOX CASE	
13	3200094	OIL SEAL	35X20X7
14	2229250	KEY	5X5X15
15	3208983	BEARING	6204
16	3209799	PINION GEAR	Z 9
17	2222145	BOLT	M 10X80 Z
18	3208919	PULLEY	
19	3208966	SPACER	
20	2223650	NUT	M 10 Z
21	2224340	WASHER	D=10 Z
22	2204569	BEARING	6211
23	2227207	CIRCLIP	E 55
24	3208970	GEAR	Z 76
25	3213282	BEARING	6208 SKF
26	3213180	LOCATING PIN	D=8X30
27	3210474	DRIVE SHAFT	
28	1227330	CIRCLIP	E 15
29	2227320	CIRCLIP	E 20



TAV. 8 - DRUM REDUCTION UNIT - WORKMAN II 350 (COD. 3209786)			
RIF.	COD.	DESCRIPTION	NOTE
1	3209428	GEAR BOX CASE	
2	3209430	COVER	
3	3213893	DUMP GEAR	M10X110 Z
4	2222465	BOLT	M5X15 Z
5	3213811	OIL SEAL RING	47X17X7
6	3209728	SCREW	M6X15
7	3213264	PINION GEAR	Z 20
8	2229259	KEY WAY	6X6X14
9	3208771	SHAFT	
10	2229300	KEY WAY	6X6X20
11	2227320	CIRCLIP	E 20
12	3208952	BEARING	6206 2Z
13	2204391	BEARING	6205 2Z
14	2204484	BEARING	6203 2Z
16	2204560	BEARING	6204 2RS
17	3209431	COVER	





EQUIPMENT WARRANTY

IMER U.S.A. INC.

3654 Enterprise Avenue
Hayward, CA 94545
Toll Free: (800) 275-5463
Office: (510) 670-7970
Fax: (510) 783-4255

We warrant to the original purchaser that the IMER equipment described herein (the "equipment") shall be free from defects in material and workmanship under normal use and service for which it was intended for period of one (1) year from the date of purchase by the original purchaser.

Our obligation under this warranty is expressly limited to replacing or repairing, free of charge, F. O.B. our designated service facility, such part of the equipment as our inspection shall disclose to be defective. Parts such as engines, motors, pumps, valves, electric motors, etc. furnished by us, but not manufactured by us, will carry only the warranty of the manufacturer. Transportation charges or duties shall be borne by purchaser. This shall be the limit of our liability with respect to the quality of the equipment.

This warranty shall not apply to any equipment, or parts thereof, which has been damaged by reason of accident, negligence, unreasonable use, faulty repairs, or which has not been maintained and operated in accordance with our printed instructions for the equipment. Further, this warranty is void if the equipment, or any of its components, is altered or modified in any way.

THIS WARRANTY IS EXPRESSLY IN LIEU OF ALL OTHER WARRANTIES, EXPRESSED OR IMPLIED, INCLUDING ANY IMPLIED WARRANTY OF MERCHANTABILITY OR FITNESS FOR A PARTICULAR PURPOSE.

We make no other warranty, representation or guarantee, nor is anyone authorized to make one on our behalf. We shall not be liable for consequential damage of any kind, including loss or damage resulting, directly or indirectly, from the use or loss of use of the machine. Without limiting the generality of the foregoing, this exclusion from liability embraces the purchaser's expenses for downtime, damages for which the purchaser may be liable to other person, damages to property, and injury or death of any persons.

This warranty shall not be deemed to cover maintenance parts, including but not limited to blades, belts, hoses, hydraulic oil, or filters, for which we shall have no responsibility or liability whatsoever.