

## Operator's Instruction Manual

# Model CPU-12



## Self-Propelled Concrete/Asphalt Planer

## READ AND UNDERSTAND THE OPERATORS INSTRUCTION MANUAL *THOROUGHLY* BEFORE ATTEMPTING TO OPERATE THIS EQUIPMENT.



Death or serious injury could occur if this machine is used improperly.



### SAFETY MESSAGES

- Safety Instructions are preceded by a graphic alert symbol of DANGER, WARNING, or CAUTION.



Indicates an imminent hazard which, if not avoided, will result in death or serious injury.



Indicates an imminent hazard which, if not avoided, can result in death or serious injury.



Indicates hazards which, if not avoided, could result in serious injury and or damage to the equipment.

### GASOLINE/PROPANE POWERED EQUIPMENT



- Engine exhaust from this product contains chemicals known to the State of California to cause cancer, birth defects or other reproductive harm.



Gasoline is extremely flammable and poisonous. It should only be dispensed in well ventilated areas, and with a cool engine.

- Small gasoline engines produce high concentrations of carbon monoxide (CO) example: a 5 HP 4 cycle engine operation in an enclosed 100,000 cu. ft. area with only one change of air per hour is capable of providing deadly concentrations of CO in less than fifteen minutes. Five changes of air in the same area will produce noxious fumes in less than 30 minutes. Gasoline or propane powered equipment should not be used in enclosed or partially enclosed areas. Symptoms of CO poisoning include, headache, nausea, weakness, dizziness, visual problems and loss of consciousness. If symptoms occur - get into fresh air and seek medical attention immediately.

### ELECTRICAL POWERED EQUIPMENT



Extreme care must be taken when operating electric models with water present: Ensure power cord is properly grounded, is attached to a Ground-Fault-Interrupter (GFI) outlet, and is undamaged.

- Check all electrical cables - be sure connections are tight and cable is continuous and in good condition. Be sure cable is correctly rated for both the operating current and voltage of this equipment.
- Improper connection of the equipment-grounding conductor can result in a risk of electric shock. Check with qualified electrician or service person if there is any doubt as to whether the outlet is properly grounded. Adhere to all local codes and ordinances.
- NOTE:** In the event of a malfunction or breakdown, grounding provides a path of least resistance for the electric current to dissipate. The motor is equipped with a grounded plug and must be connected to an outlet that is properly installed and properly grounded. DO NOT modify the plug provided on the motor. If the plug does not fit the outlet have a qualified electrician install the proper receptacle.
- Switch motor OFF **before** disconnecting power.

- Do not disconnect power by pulling cord. To disconnect, grasp the plug, not the cord.
- Unplug power cord at the machine when not in use and before servicing.

### GENERAL INSTRUCTIONS

- Equipment should only be operated by trained personnel in good physical condition and mental health (not fatigued). The operator and maintenance personnel must be physically able to handle the bulk weight and power of this equipment.
- This is a one person tool. Maintain a safe operating distance to other personnel. It is the **operators' responsibility** to keep other people (workers, pedestrians, bystanders, etc.) away during operation. Block off the work area in all directions with roping, safety netting, etc. for a safe distance. Failure to do so may result in others being injured by flying debris or exposing them to harmful dust and noise.
- This equipment is intended for commercial use only.
- For the operator's safety and the safety of others, always keep all guards in place during operation.
- Never let equipment run unattended.



- Personal Protection Equipment and proper safety attire must be worn when operating this machinery. The operator must wear approved safety equipment appropriate for the job such as hard hat and safety shoes when conditions require. Hearing protection **MUST** be used (operational noise levels of this equipment may exceed 90db). Eye protection **MUST** be worn at all times.



Keep body parts and loose clothing away from moving parts. Failure to do so could result in dismemberment or death.

- Do not modify the machine.

- Stop motor/engine when adjusting or servicing this equipment. Maintain a safe operating distance from flammable materials. Sparks from the cutting-action of this machine can ignite flammable materials or vapors.



### DUST WARNING



Some dust created by power sanding, sawing, grinding, drilling, and other construction activities contains chemicals known to cause cancer, birth defects, or other reproductive harm. Some examples of these chemicals are:

- Lead from lead-based paints, and
- Crystalline silica from bricks and concrete and other masonry products.

Your risk of exposure to these chemicals varies depending on how often you do this type of work. To reduce your risk: work in a well ventilated area, use a dust control system, such as an industrial-style vacuum, and wear approved personal safety equipment, such as a dust/particle respirator designed to filter out microscopic particles.

# Equipment Instruction Manual

## EDCO Model CPU-12

### Table of Contents

Section	Page Number
Safety Guidelines.....	4
Operating Instructions.....	5
Maintenance.....	8
Inspect & Tension Belts.....	10
Maintenance Schedule.....	11
Limited Equipment Warranty.....	back page

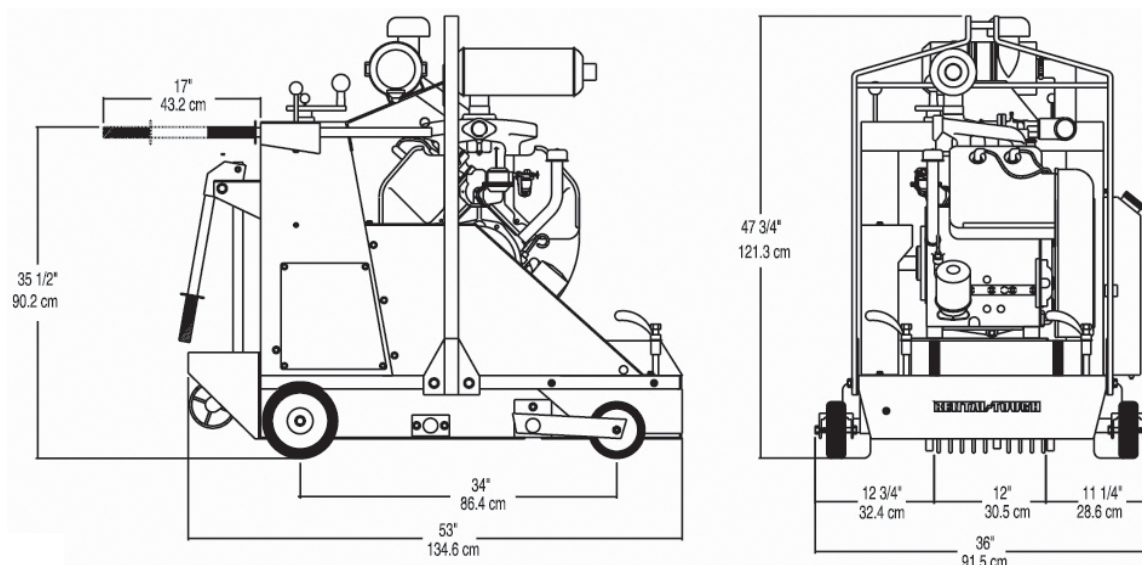

**NOTE:**

Due to design changes and improvements your machine may appear different than ones pictured in this manual. The functionality remains the same.

**Figure 1**

#### HOW TO ORDER REPAIR PARTS

To insure product safety and reliability, always use genuine EDCO replacement parts when making repairs to the equipment.

When ordering parts, please specify the MODEL and SERIAL NUMBER of the machine as given on the NAME-PLATE. In addition, give part number, description and quantity as listed on the parts list.

Please note: Due to improvements and changes in the equipment the illustrations shown may be different from the actual machine.

Toll Free: Voice 1-800-638-3326 • Fax 1-800-447-3326

Specifications for the CPU-12 are approximate and subject to change.

Height	47 3/4"	121.3 cm
Width	36"	91.5 cm
Length	53"	134.6cm
Weight	800 lbs.	362.8 kg



100 Thomas Johnson Drive, Frederick, MD 21702-4600 USA  
 Phone (301) 663-1600 • 1-800-638-3326  
 Fax (301) 663-1607 • 1-800-447-3326  
 Website: www.edcoinc.com  
 Email: sales@edcoinc.com

Printed in USA

©2013

**Page 3**



Read and understand the *Operator's Manual*, and the  
*Engine Manufacturer's Owner's Manual*  
before operating this equipment.



Death or serious injury can result if this machine is used improperly.



## Safety Guidelines



Maintain a safe operating distance from flammable materials. Sparks from the cutting-action of this machine can ignite flammable materials or vapors.



Operator must wear appropriate clothing and footwear. Do not wear loose clothing or jewelry that can get tangled or caught in moving parts. Steel toe safety shoes must be worn.



Eye and ear protection must be worn at all times when this machine is in use. During normal use, sound levels exceed 92dB. Use only ANSI approved safety glasses to help prevent eye injury. Everyday eyeglasses have only impact resistant lenses; they are NOT safety glasses.



Breathing protection is required when dry cutting.

- Keep a safe operating distance from other personnel and never leave the machine running unattended.
- Maintain the machine in safe operating condition with all guards in place and secure, all mechanical fasteners tight, all controls in working order and the scarifier configured for the job application.
- The CPU-12 is designed to plane flat horizontal concrete or asphalt slabs.
- The CPU-12 is to be operated by a single operator from a position at the rear of the machine.
- Avoid deck inserts, pipes, columns, openings, electrical outlets, or any objects protruding from slab surface.
- Inspect the cutters carefully before installing. Do not use any questionable cutters since serious personal injury and/or damage to property can result.
- Never operate this machine while under the influence of drugs, alcohol or when taking medications that impair the senses or reactions, or when excessively tired or under stress.
- Be sure all safety decals on the machine can be clearly read and understood. Replace damaged or missing decals immediately.

Safety warnings and guidelines do not by themselves eliminate danger.  
They are not given as substitutes for proper accident prevention and good judgement.

# Operating Instructions

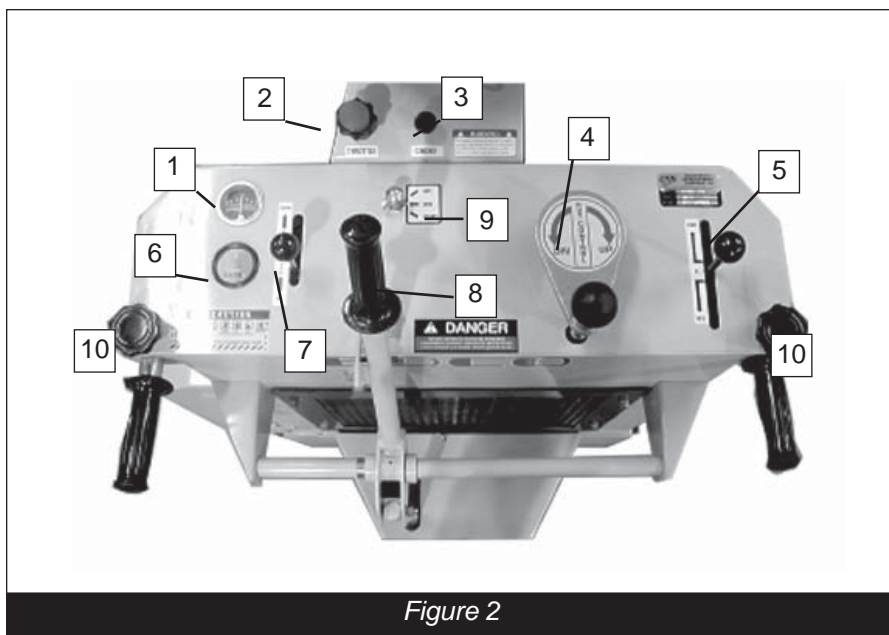

Figure 2

1. Ammeter
2. Throttle
3. Choke
4. Depth Control Knob
5. Drive Control Lever
6. Hour Meter
7. Hydraulic Drum Lift Lever
8. Cam Lift Lever
9. Ignition Switch
10. Handle Lock

## Before Starting the Engine:

- Inspect machine before each use according to the *Maintenance Schedule* on page 11.
- Locate and be familiar with all engine and operating controls (*Figure 2*).
- Inspect cutters carefully before installing. Use the correct drum assembly configuration for the job. Make sure drum assemblies are correctly mounted.
- Adjust the extendable handles for operator comfort and safe operation. Be sure to retighten handle locks once handles are positioned. (*Figure 2*, Item #10)
- Be sure cutter head is raised to the full “up” position using the drum lift lever on the console. (*Figure 2*, Item #7) This EDCO Scarifier uses a battery powered hydraulic pump.
- Lift up on the cam lift lever to lower the rear wheel, this action raises the drive wheels. Manuver the machine into position over the work area.
- Lower the cam lift lever to raise the third wheel, engaging the drive wheels.



Never lower cutter head with rear wheel raised or raise the rear wheel while the cutter head is lowered. Death or serious personal injury and/or damage to the equipment can result.

**For Gasoline Models:** Units are shipped new from the factory without gasoline or oil, it will need to be added before it is used. Check the *Engine Manufacturer's Owner's Manual* for instructions on break-in, servicing and use of engine.

**For Electric Models:** Be sure the “off” button is depressed before hooking up power source. If the cord does not mate with the connector provided, consult a qualified licensed electrician before continuing. Do not alter the plug or force it to fit. Verify that the equipment is properly grounded.

## **Starting the Engine/Motor and Controlling the Cut:**

- Be sure drum is clear of the ground.
- Start the engine according to the manufacturer's instructions. For electric models, depress "On" switch.
- Engine must be at FULL THROTTLE.
- Slowly lower the cutter head to the slab surface with the hydraulic drum lift lever. Lift the depth control handwheel knob to unlock and turn to the handwheel until the cutter head reaches the desired depth.

- CAUTION** - Never plane deeper than the maximum depth of surface removal for the assembly being used. If it is necessary to remove a deep layer of material, make several shallow passes to achieve desired depth.
- Only cut in a forward direction.
  - Always cut with the engine at full throttle.

**NOTE:** The engine/motor should not labor. Adjust forward speed to fit the work being performed. Very hard concrete will have to be planed at a slower pace than asphalt or deteriorated surfaces. If it is necessary to make deep passes, make several shallow cuts to achieve the desired depth.

- If front wheels are not in contact with slab surface when planing, you are bottoming the cutter head. You are riding on the drum & cutter wheels. Cutter wheels will wear uneven or break if this is continued. Readjust depth - turn fine adjustment in "up" direction until cutters are free and cutting is being accomplished by "hammering" action only.

- CAUTION** Failure to follow these instructions will cause undue cutter wear, breakage, bearing failure or excessive vibration that will be transmitted back to the machine frame and engine eventually causing a virtual self-destruction of the unit.

## **Controlling Speed:**

- The CPU-12 uses a hydrostatic transmission and positive chain drive mechanism to power both rear wheels to achieve forward and reverse movement. Machine speed is controlled by using the speed control lever. The lever is spring loaded and returns to neutral when released. Actual cutting speed is determined by hardness of the material and depth of desired removal. Adjust forward speed to meet working conditions.

## **To Stop Cutting:**

- Move drive control lever to neutral.
- Raise cutter head assembly using the hydraulic drum lift lever to clear the slab surface.

**For Gasoline Models:** Close throttle and turn the ignition switch to the "off" position.

**For Electric Models:** Depress the "off" button.

## **After Operation:**

- Clean the entire machine after it has cooled. Check for worn or damaged cutters and perform any required maintenance. See maintenance instructions.

## Additional Information:

- Since cutter wheels wear, the cutting depth will change. Compensate for wear by adjusting the depth control. To reach greater depth in the concrete it is best to make several passes at increments of 1/8" to 3/16" per pass. Never use a fine spaced cutter head to cut deeper than 1/8". All deep cuts should be started from a stationary position. When the cutting depth is reached the plane should then move forward.
- The cutter wheels have an oversized arbor hole (1/4" larger diameter than the shaft diameter on which it is mounted). This "play" is needed to absorb some of the shock of the cutter contacting the concrete. If the cutting depth is set too deep the cutter wheels will not be able to absorb the shock and damage to the equipment will result.
- For general use, EDCO recommends the use of tungsten carbide cutter wheels (CP-408-TV).

## Concrete:

- Some concrete slabs, especially if they are covered with water a good deal of time or if they have been treated with hardeners, develop an extremely hard surface. Material removal depth should not exceed 1/8" per pass thus may require several passes to reach the desired depth of cut.

## Asphalt:

- When cutting asphalt, depths of 1/4" per pass can be reached using a medium set up. Let the job requirements guide your selection of cutter spacing. Deep cuts require wide cutter spacing. Asphalt will usually break out between cutters and a fairly uniform clean cut is the result. Specific information on asphalt cutting is available from EDCO upon request.

## Thermoplastic Lines:

- The EDCO CPU-12 model is ideally suited to remove thermoplastic lines - the upcut feature removes the plastic from the surface by "milling" or lifting. In excessively hot weather it may be necessary to sweep the plastic away from in front of the planer. Hot plastic can build up on the wheels changing the cutting depth setting. To keep the thermo plastic from heating up, we recommend that whenever possible water be sprayed on the work surface.

Maximum Depth of Cutter Wheels
CP-405 cutter wheels have a maximum depth of 3/4" when new (hi-carbon).
CP-404 cutter wheels have a maximum depth of 1/2" when new (hi-carbon)



Remove all rings, watches and jewelry prior to doing maintenance near the hydraulic pump.



## Maintenance

Refer to the engine manual for maintenance information specific to the engine used.

### WARNING

Disconnect the machine from the power source. Remove the spark plug lead on the gasoline engine models or disconnect the supply voltage connector on the electric models, before performing any maintenance. All maintenance should be performed regularly by qualified personnel.

### WARNING

Never work under equipment without first placing chocks on the wheels and support device under the equipment to prevent it from moving or falling. Always work on a flat and level surface.

### Before Each Operation:

- Perform a visual inspection of the entire machine before operation.
- Verify all fasteners are tight and secure; check for signs of metal cracking or fatigue.
- Inspect for damage to electrical wiring or damage to fuel lines.
- Check bearings and inspect to be sure proper guards are in place and secure.
- Check oil level - fill if necessary.

### Important!

- Grease cutter bearings after every 4 hours of use, grease remaining bearings every 40-50 hours of use.

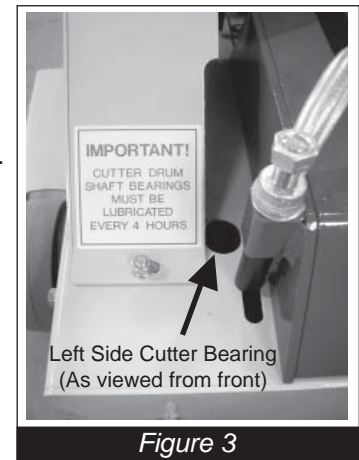

Figure 3

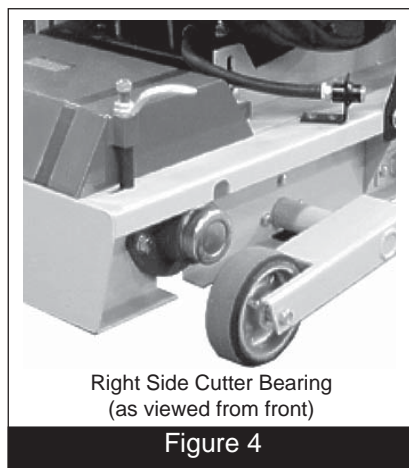

Figure 4

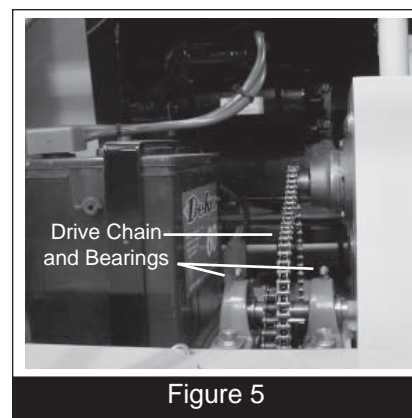
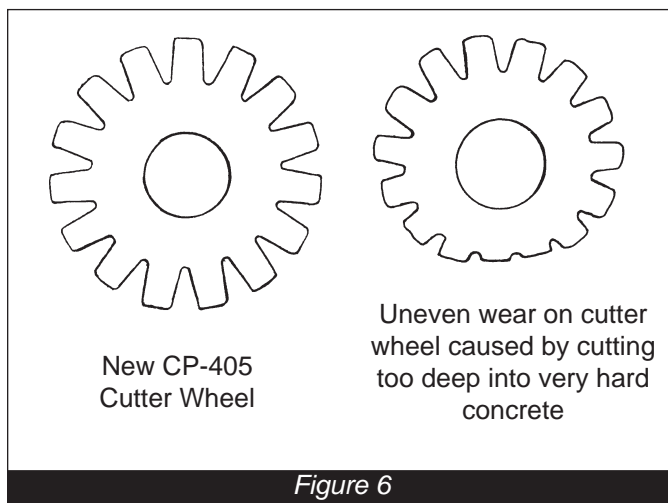

Figure 5



## Cutter Wheel Inspection:

- The steel cutter wheels can be used as long as the teeth can be clearly seen on each cutter wheel and the cutter wheel edge must be clearly above the drum flange edge when pushed towards the drum center. Replace worn out cutter wheels as a complete set.
- When changing cutters, check drum assembly for cracks or other damage. Replace bent or worn cutter shafts or cracked drum assemblies. A maximum of 30% wear on shafts before they must be replaced. Excessive vibration caused by an out of balance cutter head will cause premature failure of the bearings and fatigue cracks in weld joints and frames. Do not use damaged or unsafe equipment; repair or replace all damaged parts before proceeding with operations.



## Cutter Shaft Installation:

**CAUTION** Be sure to disconnect spark plug wires or the electrical power before changing cutters.

- Rotate Drum Assembly to expose shaft opening above frame.
- Insert shaft thru hole and install cutters as required.
- Rotate drum again to expose the next hole and repeat process.
- Position lock plate over two shafts and tighten down with capscrews and lockwashers.

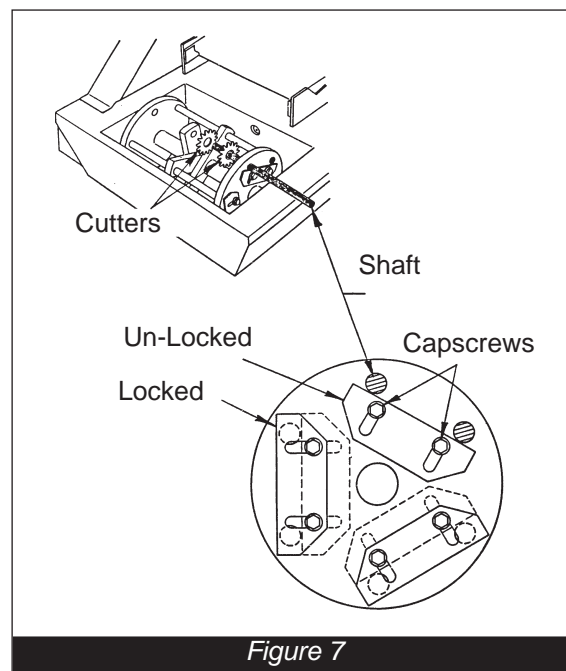

## Inspect & Tension Belts:

- Proper belt tension must be maintained to transmit the engine power to the cutter drum. Slipping belts will over heat, the cutter life will be shortened and the cutting speed limited. Over tensioned belts will shorten the belt and bearing life. 70 ft. lbs. of deflection at the center between the pulley's, is recommended.

### !! IMPORTANT!!

After tensioning belts make sure engine is level and then tighten ***all*** mounting hardware and ***jam nuts***.

- On new machines and after installation of new belts, adjust belt tension after the first four hours, then tension as necessary.

## To Tension Belts:

- Loosen engine/motor mounting hardware slightly. (Figure 8)
- Use the two jack-screw belt tensioning bolts to adjust the engine/motor until the belts are tight. Re-torque the mounting hardware.

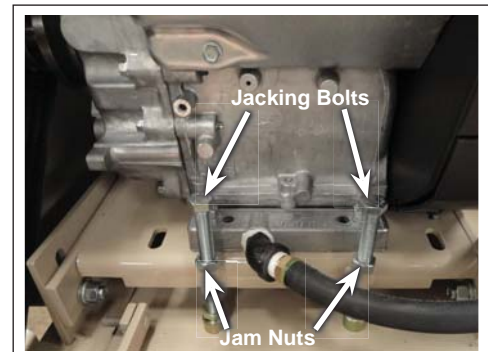

Figure 8

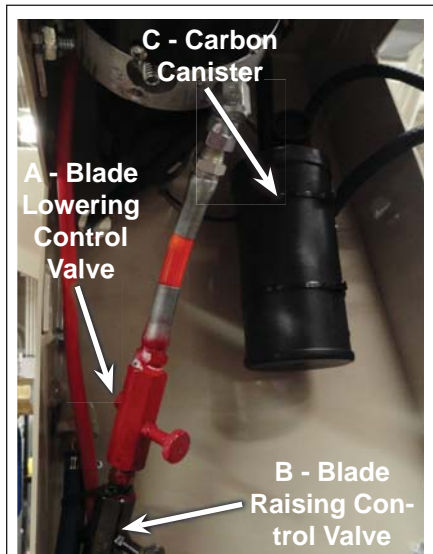

Figure 9

### **WARNING**

Remember to remove all rings, watches and jewelry prior to doing maintenance near hydraulic pump!

### **Blade Lift Controls:** (Figure 9) (Controls Hydraulic Fluid Flow)

A - (Red) Blade Lowering Control Valve

To re-adjust:

- Turn Knob  
    out-fast  
    in-slow
- Retighten lock nut

B- (Black) Blade Raising Control Valve

C- Carbon Canister



Repairs are to be done by authorized EDCO DEALERS only.



Read and follow instructions in the Engine Manufacturer's Manual

## Maintenance Schedule

Follow Engine Manufacturer's Maintenance Schedule	Before Operation	Every 4 Hours	Daily	Every 50 Hours	As Required
Visual Inspection of Entire Machine	X				
Check Engine Oil	X				
Inspect Cutter Shafts & Wheels	X				
Inspect Drum Bushings	X				
<b>Grease Cutter Assembly Bearings</b>		X			
Clean Off Machine			X		
Clean Air Filter Element			X		
Grease All Other Bearings				X	
Change Engine Oil (Refer to engine manual)				X	
Inspect Belts (Tension after the first 4 hours, then as needed)					X

**LIMITED EQUIPMENT WARRANTY OF SALE – TERMS & CONDITIONS**

Equipment Development Company, Inc. herein referred to as EDCO (Seller) warrants that each new unit manufactured by EDCO to be free from defects in material and workmanship in normal use and service for a period of (90) ninety days (except for the cutter drum assembly on all model concrete/asphalt planes, in which case the warranty period shall be 90 days) from date of shipment to the original retail or equipment rental center owner.

Accessories or equipment furnished and installed on the product by EDCO but manufactured by others, including, but not limited to engines, motors, electrical components, transmissions etc., shall carry the accessory manufacturers own warranty.

EDCO will, at its option, repair or replace, at the EDCO factory or at a point designated by EDCO, any part which shall appear to the satisfaction of EDCO inspection to have been defective in material or workmanship.

EDCO reserves the right to modify, alter and improve any part or parts without incurring any obligation to replace any part or parts previously sold without such modified, altered or improved part or parts.

This warranty is in lieu of and excludes all other warranties, expressed, implied, statutory, or otherwise created under applicable law including, but not limited to the warranty of merchantability and the warranty of fitness for a particular purpose in no event shall seller or the manufacturer of the product be liable for special, incidental, or consequential damages, including loss of profits, whether or not caused by or resulting from the negligence of seller and/or the manufacturer of the product unless specifically provided herein. In addition, this warranty shall not apply to any products or portions thereof which have been subjected to abuse, misuse, improper installation, maintenance, or operation, electrical failure or abnormal conditions and to products which have been tampered with, altered, modified, repaired, reworked by anyone not approved by seller or used in any manner inconsistent with the provisions of the above or any instructions or specifications provided with or for the product

**FORCE MAJEURE**

Seller's obligation hereunder are subject to, and Seller shall not be held responsible for, any delay or failure to make delivery of all or any part of the Product due to labor difficulties, fires, casualties, accidents, acts of the elements, acts of God, transportation difficulties, delays by a common carrier, inability to obtain Product, materials or components or qualified labor sufficient to timely perform part of or all of the obligations contained in these terms and conditions, governmental regulations or actions, strikes, damage to or destruction in whole or part of manufacturing plant, riots, terrorist attacks or incidents, civil commotions, warlike conditions, flood, tidal waves, typhoon, hurricane, earthquake, lightning, explosion or any other causes, contingencies or circumstances within or without the United States not subject to the Seller's control which prevent or hinder the manufacture or delivery of the Products or make the fulfillment of these terms and conditions impracticable. In the event of the occurrence of any of the foregoing, at the option of Seller, Seller shall be excused from the performance under these Terms and Conditions, or the performance of the Seller shall be correspondingly extended.

This document sets forth the terms and conditions pursuant to which the purchaser ("Purchaser") will purchase and Equipment Development Co. Inc. ("Seller") will sell the products, accessories, attachments (collectively the Products") ordered by the Purchaser. These terms and conditions shall govern and apply to the sale of Seller's Products to Purchaser, regardless of any terms and conditions appearing on any purchase order or other forms submitted by Purchaser to Seller, or the inconsistency of any terms therein and herein.

**1. PRICE**

All prices set forth on any purchase order or other document are F.O.B. Sellers facility or distribution point, as may be determined by Seller (F.O.B. Point). All prices are exclusive of any and all taxes, including, but not limited to, excise, sales, use, property or transportation taxes related to the sale or use of the Products, now or hereafter imposed, together with all penalties and expenses. Purchaser shall be responsible for collecting and/or paying any and all such taxes, whether or not they are stated in any invoice for the Products. Unless otherwise specified herein, all prices are exclusive of inland transportation, freight, insurance and other costs and expenses relating to the shipment of the Products from the F.O.B. point to Purchaser's facility. Any prepayment by Seller of freight insurance and other costs shall be for the account of Purchaser and shall be repaid to Seller.

**2. PAYMENT TERMS**

Payment terms are as follows. 2% 10 days (to approved and qualified accounts). Net 30 days. This is a cash discount for invoices paid within 10 days after the invoice date, regardless of date of receipt of shipment. This is not a trade discount and will not be granted to accounts that do not adhere to stated terms.

\*All past due accounts are subject to a late payment fee of 1.5% per month or a maximum allowed by law if different, along with the expenses incidental to collection including reasonable attorney's fees and costs.

\*Seller reserves the right to hold shipments against past due accounts.

\*Seller reserves the right to alter payment terms.

**3. FREIGHT TERMS**

All shipments will be made F.O.B. shipping point as designated in these Terms and Conditions, and title shall pass at the F.O.B. point. Delivery to the initial common carrier shall constitute delivery to the Purchaser. Any claims for loss or damage during shipment are to be filed with carrier by the Purchaser. Seller will not assume responsibility for the performance of the carrier.

Back orders will be shipped in the most practical fashion with charges consistent with our freight policy established with the original order. UPS, FED EX, MAIL or shipments by other couriers are subject to the same terms and conditions as outlined in paragraph #3 "Freight Terms".

**4. DELIVERY, DAMAGES, SHORTAGES**

Seller shall use reasonable efforts to attempt to cause the Products to be delivered as provided for in these Terms & Conditions. Delivery to the initial common carrier shall constitute the delivery to the Purchaser. Seller's responsibility, in so far as transportation risks are concerned ceases upon the delivery of the Products in good condition to such carrier at the F.O.B. point and all the Products shall be shipped at the Purchaser's risk. Seller shall not be responsible or liable for any loss of income and/or profits, or incidental, special, consequential damages resulting from Seller's delayed performance in shipment and delivery.

**5. RETURN OF DEFECTIVE PRODUCTS**

Defective or failed material shall be held at the Purchaser's premises until authorization has been granted by Seller to return or dispose of Products. Products that are to be returned for final inspection must be returned Freight Prepaid in the most economical way. Credit will be issued for material found to be defective upon Seller's inspection based on prices at time of purchase.

**6. PRODUCTS ORDERED IN ERROR**

Products may be returned, provided that claim is made and Seller is notified within 7 days of receipt of Products, and the Products are in original buyer's possession not more than 30 days prior to return, subject to Seller's approval. If Products are accepted for return, they must be Freight Prepaid and buyer will be charged a minimum of 15% restocking charge, plus a charge back for outbound freight charges if the original order was shipped prepaid. Returns are not accepted for any Products that are specifically manufactured to meet the buyer's requirement of either specifications or quantity.

**AGREEMENTS**

These Terms and Conditions constitute the entire agreement between Seller and Purchaser as it relates to terms and conditions of sale, and supersedes any and all prior oral or written agreements, correspondence, quotations or understandings heretofore in force between the parties relating to the subject matter hereof. There are no agreements between Seller and Purchaser with respect to the Product herein except those specifically set forth in and made part of these terms and conditions. Any additional terms, conditions and/or prices are rejected by Seller.

These terms and conditions may be modified, cancelled or rescinded only by a written agreement of both parties executed by their duly authorized agents.

**USE ONLY GENUINE EDCO PARTS & ACCESSORIES**  
**For your own safety, the safety of others and the life of your machine.**  
**Equipment Development Company, Inc.**